

# Biological and Behavioral Response Studies of Marine Mammals in Southern California, 2011 ("SOCAL-11")

## ***FINAL PROJECT REPORT*** ***8 March 2012***

B. Southall, J. Calambokidis, P. Tyack, D. Moretti, A. Friedlaender, S. DeRuiter, J. Goldbogen, E. Falcone, G. Schorr, A. Douglas, A. Stimpert, J. Hildebrand, C. Kyburg, R. Carlson, T. Yack, J. Barlow



**SOCAL-11 Project Report – *Table of contents***

<b>1. EXECUTIVE SUMMARY</b>	<b>3</b>
<b>2. PROJECT OBJECTIVES</b>	<b>4</b>
<b>3. METHODOLOGY AND FOCAL SPECIES</b>	<b>4</b>
<b>4. OPERATIONAL AREAS AND TIMING</b>	<b>7</b>
<b>5. VISUAL SURVEY RESULTS</b>	<b>9</b>
<b>6. SUMMARY OF TAG DEPLOYMENTS</b>	<b>14</b>
<b>7. CONTROLLED EXPOSURE EXPERIMENTS</b>	<b>16</b>
<b>8. OVERALL ASSESSMENT OF ACCOMPLISHMENTS VS. OBJECTIVES</b>	<b>31</b>
<b>9. SOCAL-10 TRANSPARENCY AND PUBLIC IMPACT</b>	<b>32</b>
<b>10. CONCLUSIONS AND NEXT STEPS</b>	<b>33</b>
<b>APPENDIX I. Sound Source Testing and Verification</b>	<b>36</b>
<b>APPENDIX II. SOCAL-11 PAM Survey Report</b>	<b>45</b>



## 1. EXECUTIVE SUMMARY

SOCAL-11 was the second year of a scientific research project (planned for 2010-2015) entitled Southern California Behavioral Response Study (SOCAL-BRS) occurring in the Southern California Bight. The overall objective is to provide a better understanding of marine mammal behavior and a direct scientific basis to estimate the risk and minimize adverse effects of human sounds, particularly military sonar, on marine mammals. SOCAL-BRS extends previous studies in integrating behavioral response studies (BRS) with ongoing research on diving, foraging, and social behavior. SOCAL-BRS is closely coordinated with recent and ongoing studies in the Bahamas, Europe, and other areas, including a new joint collaboration on response metrics and analysis across projects.

Like other studies using controlled exposure experiment (CEE) methods, SOCAL-11 included an interdisciplinary collaboration of experts in various disciplines of marine biology and acoustics. During a scouting phase and two operational legs, researchers observed, photographed, and/or tracked thousands of individuals of 18 marine mammal species. Thirty-eight tags (of four kinds) were secured on 35 individual animals of four different marine mammal species. This included a large number of tags for certain focal species, including expanding the large sample size of blue whales from SOCAL-10, a greater than expected success with Risso's dolphins, and a second successful tag and CEE on a very difficult yet important species (Cuvier's beaked whale). Other species (*e.g.*, fin whales, sperm whales, Baird's beaked whales, and killer whales) that were tagged in SOCAL-10 were either not encountered or were not tagged in SOCAL-11.

Researchers conducted 18 CEEs on 18 individuals of three marine mammal species affixed with suction cup acoustic tags and tracked both visually and acoustically. Simulated military sonar signals (several orders of magnitude less intense than real sonar) and noise bands of comparable frequency (identical to SOCAL-10) were presented as experimental stimuli under very specific protocols and protective measures to ensure animals were not harmed. Changes in behavior from baseline conditions were measured as a function of sound exposure. Preliminary results based primarily on clearly observable behavior in the field and from initial data assessment were similar to those made in SOCAL-10, but extended sample size considerably in blue whales and Risso's dolphins. These preliminary results indicate variable responses (ranging from no observable response to apparent temporary avoidance behavior), depending on species, type of sound, and behavioral state during the experiments. Additional analysis and interpretation is underway of the nearly 200 hours of tag data, as well as thousands of marine mammal observations, photographs, tissue samples, and acoustic measurements. SOCAL-BRS continues to be supported by several organizations of the U.S. Navy (below) seeking better data to inform decision-making, and was closely coordinated with the U.S. National Oceanic and Atmospheric Administration (NOAA).

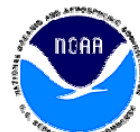

## 2. PROJECT OBJECTIVES

The overall SOCAL-BRS effort (of which SOCAL-11 was the second year) has the following overarching objective:

**“SOCAL-BRS is an interdisciplinary collaboration designed to *increase understanding of marine mammal reactions to sound and provide a more robust scientific basis for estimating impact of Navy sonar*”**

For each field season of SOCAL BRS, the research team develops a number of specific research objectives to meet this overarching goal. Some remain constant from year to year, but others may change based on progress in previous seasons, developments in technology, available resources, and other developments. For SOCAL-11, the following specific objectives were identified before field operations, against which accomplishments can be compared as a means of gauging the relative success of field operations:

- (1) *Obtain* baseline behavioral data.
- (2) *Conduct* controlled exposure experiments (CEEs) on baleen whales, beaked whales, and Risso’s dolphins.
  - Species focus to remain flexible based on conditions encountered, but emphasis on baleen whales, beaked whales, and Risso’s dolphins
  - Derivation and application of “tagless” playback approaches a priority for SOCAL-11 (target species: Risso’s dolphin)
- (3) *Test* optimal configuration for subsequent studies, which may include realistic/actual military sources; and
- (4) *Obtain* data to support the Navy’s SOCAL range monitoring

## 3. METHODOLOGY AND FOCAL SPECIES

### *SOCAL-11 General Methodology*

The overall research methods used in the SOCAL-11 project was generally quite similar to that employed in SOCAL-10, with a few differences in terms of research vessels and visual focal follow methods. The approach included standard visual sampling methodologies for detecting and tracking marine mammals, typical small boat operations for photo-identification and tagging of research subjects, acoustic monitoring using various sensors (included separate towed passive acoustics which was

## SOCAL-11 PROJECT REPORT

an additional methodology from SOCAL-10), and the use of controlled sound exposures in order to study the onset of behavioral responses. Specialized interdisciplinary teams consisting of highly experienced scientists and engineers from the research organizations listed above were again involved, using state-of-the-art tools and technologies to tag and track marine mammals and carefully and safely conduct controlled exposure experiments.

**Visual observers**, experienced in sighting marine mammals several miles away with specialized binoculars, searched for animals and monitored subjects before, during, and after CEEs. For SOCAL-11 visual observers based on the central research platform were primarily responsible for locating animals and monitoring during CEEs. Visual observers on small boats were primarily responsible for conducting dedicated focal follows of specific animals.

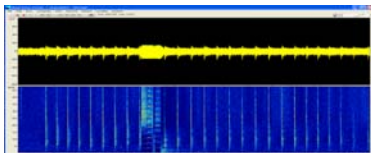

**Photo identification** was used to identify individuals sighted and involved in CEEs, based on distinct features, scars, and markings. These data are also being used within existing database catalogues for various marine mammal species along the U.S. west coast.



**Passive acoustic monitoring** utilized different listening platforms and systems (depending on the operational location and focal species) from the U.S. Navy SCORE range as well as those deployed from SOCAL-10 vessels to detect vocalizing whales and monitor sound

exposures and animal responses during CEEs. Additionally, in SOCAL-11 separate vessels using towed passive acoustic listening capabilities were employed to support the detection of vocalizing animals and to measure the received levels of the test signals at a variety of distances (see Appendix II for more detail).



**Tagging teams** carefully approached and deployed acoustic monitoring tags with non-invasive suction cups from small rigid-hull inflatable boats (RHIBs). The RHIB teams also provided visual monitoring of focal groups during baseline dives and CEEs and recorded behavioral observations in standard focal follow protocols.

## SOCAL-11 PROJECT REPORT

**Geographical Information Systems (GIS) engineers** integrated a variety of data streams (including vessel position, visual sightings, and geographic/oceanographic data) for real-time presentation on maps. These data were integrated in a software environment called the Whale Identification, Logging Display System (WILD) which was used for operational awareness and as a time-synchronized archive of all SOCAL-11 vessel movements and other data.

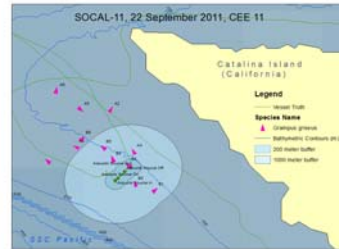

**Sound source engineers** operated a specialized underwater speaker that was used to play experimental sounds during CEEs. This relatively compact sound projector was a 15-element vertical line array developed specifically for SOCAL-BRS to enable the production of various test stimuli at sufficiently loud amplitude. Modifications and upgrades to this source from SOCAL-10 to SOCAL-11 were made and the source was re-tested and calibrated prior to field trials (see Appendix I).

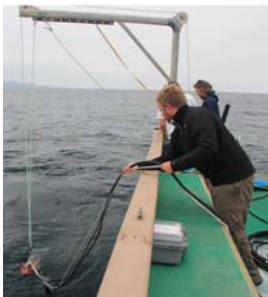
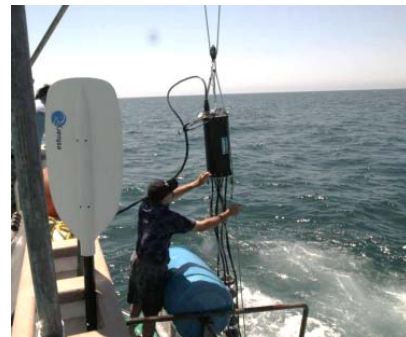

**Fisheries acoustics biologists** obtained measurements of prey distribution as a predictor of whale behavior and as a covariate in response analysis. These sampling procedures were only used in the context of mysticete cetaceans and involved high frequency sounds above their likely hearing ranges.

### *SOCAL-11 Focal Species*

This project was conducted under the terms of U.S. National Marine Fisheries Service (NMFS) research permit #14534, Channel Islands National Marine Sanctuary (CINMS) permit #2010-004 for operations within the boundaries of the CINMS, and under the terms of a consistency determination of the California Coastal Commission. As specified within permit #14534, a number of “focal” marine mammal species were authorized to be directly studied in the SOCAL-BRS project. For each species, a fixed number of “takes” of different types were permitted for different activities, including behavioral observation, close approach for photo ID, attachment of both archival acoustic and satellite-linked position monitoring tags<sup>1</sup>, and sound exposure from vessels, prey-

<sup>1</sup> Authorized under a separate NMFS permit (#540-1811).

## SOCAL-11 PROJECT REPORT

imaging active sonars, and experimental sounds used in CEEs.

For the five-year period of SOCAL BRS the following species were authorized as “focal” species for tagging and CEEs under NMFS permit #14534 (those in **bold** were identified as high priority species in SOCAL-11): **blue whale (*Balaenoptera musculus*)**, **fin whale (*Balaenoptera physalus*)**, **sperm whale (*Physeter macrocephalus*)**, **Cuvier’s beaked whale (*Ziphius cavirostris*)**, **Baird’s beaked whale (*Berardius bairdii*)**, Blainville’s beaked whale (*Mesoplodon densirostris*), short-finned pilot whale (*Globicephala macrorhynchus*), **Risso’s dolphin (*Grampus griseus*)**, **bottlenose dolphin (*Tursiops truncatus*)**, Pacific white-sided dolphin (*Lagenorhynchus obliquidens*), **short or long-beaked common dolphin (*Delphinus sp.*)**, northern right whale dolphin (*Lissodelphis borealis*), California sea lion (*Zalophus californianus*), northern elephant seal (*Mirounga angustirostris*), and harbor seal (*Phoca vitulina*). As described in greater detail below, during SOCAL-11 most of high-priority focal species were encountered and some were included in the overall research effort.

We were not authorized to focus tagging or CEEs on other marine mammal species occurring in southern California waters. However, the permit and accompanying environmental assessment did consider potential impacts of incidental exposure to sounds during CEEs although this could not occur within a specified range (1000m).

### 4. OPERATIONAL AREAS & TIMING

The SOCAL-BRS general operational area includes both southern and northern “inshore” areas around southern California and an offshore area that includes the U.S. Navy’s SCORE range (see figure to right). During SOCAL-10 and SOCAL-11, operations have occurred throughout all parts of this region (with any sound transmissions occurring at least 1 nm from shore in any area and at least 3 nm from any land mass within the CINMS).



SOCAL-11 was conducted in three distinct segments, a “scouting leg” and two experimental phases (hereafter “Leg I” and “Leg II”). Each of these legs involved slightly different configurations, operational areas, and somewhat different objectives. For each of these



segments, the *R/V Truth* (right: a ~70-foot dive charter vessel converted for use in this research project with a specialized observation platform and other modifications) was used as a base of operations in conjunction with the two ~6m inflatable tagging boats with twin outboard engines (left).



## SOCAL-11 PROJECT REPORT

The **SOCAL-11 scouting leg** was conducted from **July 15 – 26 (12 days)**. The purpose of the scouting leg was to determine the general distribution and abundance of focal species for experimental leg I, to test the overall configuration and train new personnel, and to use passive listening sensors to try and identify deep water areas for possible beaked whale studies outside the Navy's SCORE range.

As seen in the GIS figure to the right, during the scouting leg, the *Truth* (green track) and a single scouting RHIB (Ziphid - red track) surveyed areas around the northern Channel Islands, offshore areas in the Santa Cruz Basin and around some of the southern Channel Islands. Weather conditions and other activities on the SCORE range precluded scouting operations in areas to the west of San Clemente Island.

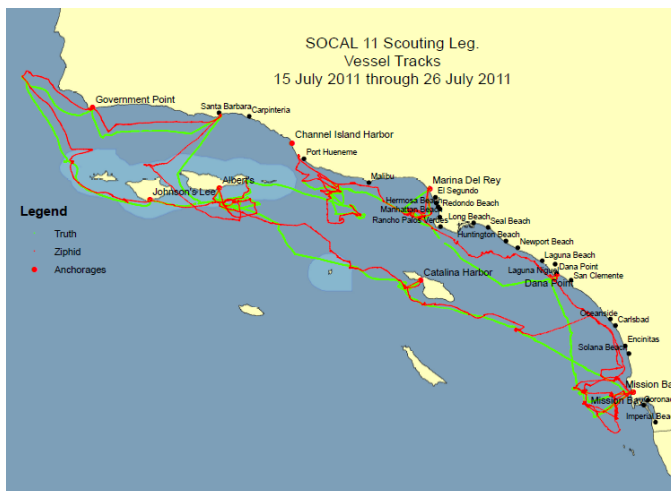

Additionally, the scouting leg included a near-shore track from San Diego back up to the Long Beach/L.A. area, returning to Santa Barbara.

**SOCAL-11 experimental leg I** was conducted from **July 29-August 11 (14 days)**. As seen in map to the right (tracks of both the *Truth* and two RHIBs are shown – see legend), operations generally occurred in areas around Point Conception for the first few days and then in offshore areas in the Santa Cruz and San Pedro basins and, when conditions were poor in near-shore areas around Palos Verdes, Long Beach, Oceanside, and San Diego.

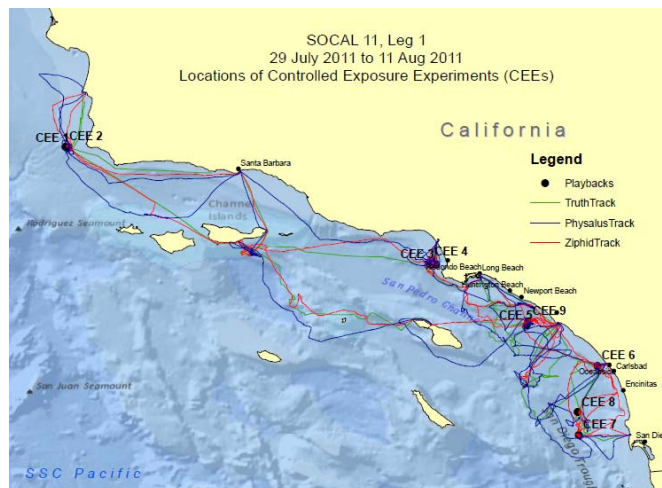

Favorable offshore conditions on some days resulted in operations focused on more pelagic species including beaked whales and Risso's dolphins. We had some success in detecting each species, although only isolated sightings of individual beaked whales were made in the shallower canyons; tagging and CEEs of Risso's dolphins were conducted in leg I. Without the right combination of favorable weather conditions and access to the SCORE range without other operations, Leg I operations did not utilize the range areas. There was some emphasis on baleen whales when offshore conditions



## SOCAL-11 PROJECT REPORT

were not favorable (or in some cases one RHIB would focus more offshore and another would focus on baleen whales nearer to shore). However, there was also an explicit effort to focus on baleen whales in deeper water areas as well, which was realized for blue whales in several instances in some of the basins near the CA mainland. Baleen whales were present in less dense coastal aggregations in SOCAL-11 vs. SOCAL-10, which made efforts on fin whales more difficult and we had very few fin whale encounters and no tags were deployed on this species in leg I. A total of nine CEEs were conducted in leg I on blue whales and Risso's dolphins.

**SOCAL-11 experimental leg II** was conducted from **September 17 – 30 (14 days)**. As was the case in SOCAL-10, more favorable offshore weather conditions were

experienced in this leg later in the season. As seen in the GIS track of the Truth and RHIBs in the figure to the right, this leg focused effort primarily in deep offshore areas of the Santa Cruz Basin and in the San Pedro Channel and Basin between Palos Verdes peninsula and Catalina Island. With the favorable offshore conditions, focus in these areas was primarily on Cuvier's beaked whales and Risso's dolphins, with successful tag attachments and CEEs on each species (discussed in greater detail in

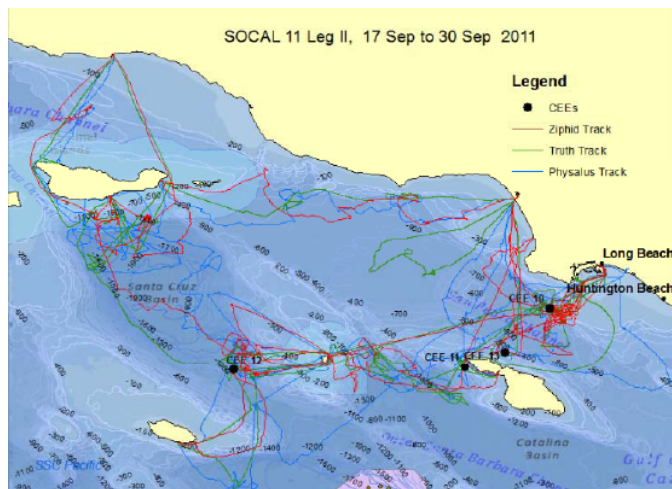

sections below). Sperm whales were detected acoustically during leg II on several occasions, but were not detected visually. High levels of Navy activity precluded use of the SCORE range off San Clemente Island and in some cases influenced operations in areas of the Santa Cruz Basin where operational sonar was detected well above background noise. A total of four CEEs were conducted in leg II on Risso's dolphins and Cuvier's beaked whales.

## 5. VISUAL SURVEY RESULTS

Trained and experienced marine mammal visual observers were used both on the central research vessel (*R/V Truth*) and on the RHIBs during all phases of SOCAL-11. The use of visual observers from the RHIBs to conduct behavioral focal follows of tagged individuals before, during, and after CEEs was a significant evolution from SOCAL-10. Visual observers were on duty from all platforms during essentially all daylight hours when weather and sea conditions permitted and operated in three different operational modes (modified slightly from SOCAL-10), including:

## SOCAL-11 PROJECT REPORT

**Survey Mode** – a general search mode to locate possible focal individual(s)

**Focal Follow Mode** – a dedicated tracking of specific individual(s)

**Mitigation Mode** – visual survey of an area before, during, and just after CEEs to meet specified safety protocols and determine incidental “takes” of non-focal marine mammals for compliance with research permits

On the *Truth*, a rotating team of 2-3 trained and experienced visual observers were based on an elevated (~6m) observation platform with a 360° field of view. These observers used handheld reticle binoculars (7X50 Fujinon and 15X80 Steiner) and an angle board to determine range and bearing of sightings for entry into the specialized geospatial software system (WILD). The *Truth* visual observers were most commonly in survey mode, searching for candidate species for potential tagging, communicating information about sighting between platforms, and in some cases obtaining photo ID samples. The *Truth* maintained position approximately 1000m from tagged focal animals before, during, and after CEEs. While the RHIBs were primarily responsible for conventional focal follows, individuals and/or groups that were re-sighted were coded accordingly within WILD, keyed to the RHIB sighting numbers where appropriate. In these cases, the following behavioral observations were collected:

- Initial surface and terminal dive times of specific focal follow animal or focal group
- Aspect in relation to vessel and sound source
- General behavior - slow/fast travel, milling, feeding, dis/affiliation, tail slap, breach etc
- Group envelope
- Age class(es)

This variant of conventional focal follow protocols enabled the *Truth* observers to accurately track animals or groups to provide a reliable estimate of potential incidental exposures for permit requirements during CEEs. Additionally, efforts were made to test protocols for focal follows of groups of smaller odontocete cetaceans from the *Truth* in preparation for potential sound playbacks in which animals were not tagged. In this case, group sampling procedures were used and *Truth* observers conducted focal follows. Three dedicated trials of these procedures were used (discussed more below), but no actual “tagless” playbacks were conducted in SOCAL-11. Finally, during CEEs, visual observers ensured all specified shutdown conditions were met by monitoring the specified safety radius and providing 360° visual coverage for any abnormal behavioral responses in focal or non-focal animals.

Prior to selection of focal animals or groups as subjects for tagging or focal follow, RHIB observers searched widely in survey mode as well. Once a focal follow was initiated,

## SOCAL-11 PROJECT REPORT

typically once a subject was tagged, observers from the RHIBs used primarily naked eye observations given their range to focal animals (~100-200m). During and following CEEs, RHIB observers were responsible for maintaining focal follows of specified individuals to provide information about range, bearing and behavior of focal animals. Additionally, RHIBs were in constant communication with the *Truth* regarding any conditions that would require shutdown of CEEs; RHIB observers thus contributed to mitigation mode during CEEs as well.

Across each operational leg and observational modes, below are the summarized visual survey results for SOCAL-11 from both the *Truth* and RHIB visual observers.

### Preliminary SOCAL-11 Results from *Truth* Visual Observer Team

	Scouting	Leg I	Leg II
Number Survey Days	12	14	14
Survey Sightings *	226	273	195
Focal Follows (> 1 resight)	4	36	31
Number of mar. mam. Species	14	15	11
Best est. of number Individuals *	3,411	4,389	4,676
Number of groups photographed	35	55	38
Est. blue whale Photo-ID	8	27	10

### Preliminary SOCAL-11 Results from RHIB Visual Observations

Vessel	Survey Days	Survey Hours	Survey Distance (nm)	Total Mammal Sightings
Physalus	28	287	2577	144
Ziphid	40	439	3343	381
<b>TOTAL RHIBs</b>	<b>68</b>	<b>726</b>	<b>5919</b>	<b>525</b>



SOCAL-11 PROJECT REPORT

**Summary of conditions and results of group focal follow efforts**

Trial #	Ocean Conditions	Group size	Group spread	Group Track	Group Behavior	Success?
I (Dc)	Bft 2, 1-2 m swell	20	cohesive	Erratic	Rest + Travel	NO
II (Dc)	Bft 1, 1-2 m swell	24	cohesive	Circling	Travel + Feeding	YES
III (Tt)	Bft 1, 0-1 m sw	25	>> spread out (>1 km)	Directional	Slow Travel	NO

The overall assessment of the feasibility of these methods, based on these trials, is as follows. In terms of group selection, the main limiting factors were group spread and marginal sighting conditions. As seen above, in conditions of loose group cohesion and even small increases in sea state led to failure in maintaining the group focal follow for durations required to conduct tagless playbacks. Future efforts should focus on groups with moderate to high cohesion in conditions of Beaufort sea state 2 or less with <2m swell. Finally, the use of a single, stationary vessel for both tracking focal groups and conducting CEEs is deemed to be quite difficult, owing to challenges in maintaining a consistent observation (especially if animals respond with avoidance) and reduced accuracy in tracking of location relative to ship's heading.

As a general summary to visual sampling in SOCAL-11, modifications to visual survey methodologies were highly successful. They enabled broad areas to be covered with cross-platform communication in survey mode and reduced redundancy in naming of the same group with different identifiers from different platforms. Mini-big eye (15X80) binoculars worked well in calm conditions from the mount implemented for SOCAL-11 and aided in the detection of beaked whales on multiple occasions. Methods ensured effective tracking of whales in areas where CEEs were conducted and supported several specified shut-downs of sound source (discussed below). Adaptations of other methods for group sampling were also readily integrated into the Truth visual observer protocols, thanks in part to modifications of WILD supporting data entry. Finally, visual observers were extremely useful in implementing shut-down procedures of CEEs in full compliance with protocols and authorizations when animals came within specified safety radii.

## 6. SUMMARY OF TAG DEPLOYMENTS

A similar suite of acoustic and movement tags were used in SOCAL-11 as in previous projects, each with somewhat different capabilities and thus intended functions. These included:



*DTAGs* – designed and supplied by WHOI collaborators<sup>2</sup>, these tags are attached with suction cups for up to tens of hours, recording continuous broadband received sound (variable from ~100Hz up to 250 kHz) as well as depth and 3-D acceleration. Both version II Dtags (used in SOCAL-10) and new version III Dtags were used in SOCAL-11.



*Mk-10s*<sup>3</sup> – designed by Wildlife computers, these tags are also attached with suction cups for temporary attachments of up to tens of hours; they measure dive characteristics and GPS positions when the animal is at the surface.

*ACOUSONDES*<sup>4</sup> – these suction cup-attached tages from Greeneridge Sciences, Inc. provide digital sound (variable from ~20Hz to 116 kHz), depth, temperature, pitch and roll angle.

*Various time-depth and satellite-linked tracking tags* used in a companion project that was coordinated with SOCAL-11

Depending on the focal species, environmental conditions, timing, and other practical considerations, different combinations of these tags were used in different circumstances. In some cases where possible for large whale species, we used dual deployments to obtain a more robust set of measurements of diving, acoustics, and geographic position. While not as prolific in terms of the total number of species and individuals as in the previous field season, SOCAL-11 managed to tag a wide variety of species and a relatively large number of individuals.

---

<sup>2</sup> Johnson, M. P., and P. L. Tyack. 2003. A Digital Acoustic Recording Tag for Measuring the Response of Wild Marine Mammals to Sound. *IEEE Journal of Oceanic Engineering* 28:3-12.

<sup>3</sup> <http://www.wildlifecomputers.com/Products.aspx?ID=34>

<sup>4</sup> <http://www.acousonde.com/>

SOCAL-11 PROJECT REPORT

Tag deployments and attachment durations in SOCAL-11

Date	Time on	Time Off	Total time	Species	Tag ID	Animal ID
29-Jul	11:17:00	17:45:00	6:28:00	Blue Whale	Dtag 224	bw11_210b
29-Jul	12:29:10	16:09:22	3:40:12	Blue Whale	Dtag 236	bw11_210a
30-Jul	9:09:41	13:37:38	4:27:57	Blue Whale	Dtag 230	bw11_211a
30-Jul	10:10:03	10:50:06	0:40:03	Blue Whale	Dtag 243	bw11_211b
31-Jul	12:42:07	12:54:16	0:12:09	Blue Whale	Dtag 230	bw11_212b
31-Jul	13:02:55	13:03:02	0:00:07	Blue Whale	Dtag 243	bw11_212a
1-Aug	8:32:29	15:52:19	7:19:50	Blue Whale	Dtag 230	bw11_213b
1-Aug	10:28:21	10:33:19	0:04:58	Blue Whale	Dtag 238	bw11_213a
2-Aug	8:32:03	9:39:32	1:07:29	Blue Whale	Dtag 238	bw11_214a
2-Aug	9:02:22	14:40:29	5:38:07	Blue Whale	Dtag 230	bw11_214b
2-Aug	10:30:04	11:25:50	0:55:46	Blue Whale	Dtag3 103	bw11_214c
3-Aug	11:20:12	12:29:44	1:09:32	Blue Whale	Dtag 238	bw11_215a
3-Aug	12:38:49	14:15:52	1:37:03	Blue Whale	Dtag3 102	bw11_215b
4-Aug	12:19:11	20:41:30	8:22:19	Rissos Dolphin	Dtag3 101	gg11_216a
6-Aug	16:24:56	19:09:30	2:44:34	Blue Whale	Dtag 236	bw11_218a
6-Aug	16:44:11	21:48:56	5:04:45	Blue Whale	Dtag 238	bw11_218b
7-Aug	14:00:07	14:46:09	0:46:02	Blue Whale	Dtag 236	bw11_219a
7-Aug	14:57:51	17:18:49	2:20:58	Blue Whale	Dtag 230	bw11_219b
8-Aug	11:00:02	16:45:00	5:44:58	Blue Whale	Dtag 236	bw11_220a
8-Aug	14:39:14	17:20:27	2:41:13	Blue Whale	Dtag 230	bw11_220b
9-Aug	11:50:00	16:55:32	5:05:32	Blue Whale	Dtag 236	bw11_221a
9-Aug	13:46:57	17:28:58	3:42:01	Blue Whale	Dtag 230	bw11_221b
20-Sep	13:08:00	13:09:00	0:01:00	Blue Whale	Dtag 238	bw11_263a
20-Sep		na	na	Rissos Dolphin	SAT TAG	gg11_263b
21-Sep	7:42:00	2:16:00	18:33:12	Blue Whale	MK-10	bw11_264a
21-Sep	8:13:00	9:37:00	25:23:38	Blue Whale	MK-10	bw11_264b
21-Sep	10:54:00	16:11:02	5:17:02	Rissos Dolphin	Dtag 238	gg11_264c
21-Sep	14:34:07	19:10:00	4:35:53	Blue Whale	MK-10	bw11_264d
21-Sep	14:34:07	17:12:00	2:37:53	Blue Whale	Dtag 238	bw11_264e
22-Sep	12:42:25	19:19:49	6:37:24	Rissos Dolphin	Dtag3 103	gg11_265a
24-Sep	7:50:04	9:00:00	1:09:56	Rissos Dolphin	Dtag3 106	gg11_267a
24-Sep	11:26:00	8:49:00	21:22:58	Cuvier's beaked whale	Dtag3 105	zc11_267a
25-Sep	16:02:23	18:18:00	2:15:37	Blue Whale	MK-10	bw11_268a
25-Sep	17:54:25	19:24:00	1:29:35	Blue Whale	MK-10	bw11_268b
26-Sep	9/26/2011 11:37	9/27/2011 4:26	16:49:10	Rissos Dolphin	Dtag3 103	gg11_269a
28-Sep	9:16:59	9:21:00	0:04:01	Bottlenose Dolphin	Dtag3 102	tt11_271a
28-Sep	11:24:30	11:51:00	0:26:30	Bottlenose Dolphin	Dtag3 102	tt11_271b
29-Sep	13:27:14	17:54:00	4:26:46	Rissos Dolphin	Dtag3 102	gg11_272a

Blue whales again comprised the largest number of individuals, although as intended many of these were animals in more typical areas and behavioral states than the surface feeding modes experienced in SOCAL-10. Fin whales were sighted and attempts were made to tag them, but these were unsuccessful. Similarly, sperm whales were detected acoustically and efforts were made to locate and tag them, but these were unsuccessful as well. Better than expected success was experienced with Risso's dolphins in SOCAL-11, with a total of six suction cup acoustic tags successfully deployed most of which lasted for many hours. Additionally, a Cuvier's beaked whale was successfully tagged for

## SOCAL-11 PROJECT REPORT

over 20 hours. Finally, suction cup acoustic tags (version III Dtags) were attached to two bottlenose dolphins, but as in previous efforts these lasted for a relatively short period of time. The summary tables given here show the breakdown of tags deployed by species within each of the SOCAL-11 experimental legs.

LEG I Tag Summary: 20 individuals of 2 marine mammal species (with 22 tags of 2 types)		
14 days	Blue Whales:	19 individuals (21 Dtags)
	Rissos dolphins:	1 individual (1 Dtag)

LEG II Tag Summary: 13 individuals of 4 marine mammal species (with 14 tags of 4 types)		
14 days	Blue Whales:	6 individuals (2 Dtags, 5 MK-10s)
	Rissos dolphins:	6 individuals (5 Dtags, 1 sat tag)
	Cuvier's Beaked Whales	1 individual (1 Dtag)
	Bottlenose Dolphins	2 individuals (2 Dtags)

**SOCAL-11 succeeded in attaching 38 tags of four different types on 35 individuals of four different marine mammal species.** For the suction cup acoustic/position tags used in SOCAL-11 (not including the satellite tags), this resulted in nearly 200 hours of tag data across these individuals, the majority resulting from Dtag deployments.

## 7. CONTROLLED EXPOSURE EXPERIMENTS (CEEs)

### *General Methodology and Sound types*

CEEs were conducted using similar methods and sound types to previous, related studies in the Bahamas in 2007-08<sup>5</sup> and to those used in SOCAL-10<sup>6</sup>. The experimental protocols are based on well-established methods of measuring behavioral responses to various stimuli using a before, during, after (A-B-A-) paradigm. Additionally, numerous safety protocols were developed and implemented regarding conditions required to initiate and continue sound exposures, in order to ensure the experiments could be completed safely without causing harm to the animals being investigated or others in the area. Each of these experimental and safety protocols are discussed in slightly greater detail here.

First, all possible means of monitoring animals (visually, acoustic tags, other passive acoustic sensors) were used to observe movement and acoustic behavior in a baseline

<sup>5</sup> Tyack, P.L., W.M.X. Zimmer, D. Moretti, B. L. Southall, D.E. Claridge, J.W. Durban, C.W. Clark, A. D'Amico, N. DiMarzio, S. Jarvis, E. McCarthy, R. Morrissey, J. Ward, I.L. Boyd. (2011). Beaked whales respond to simulated and actual navy sonar. PLoS ONE 6(3): e17009. doi:10.1371/journal.pone.0017009.

<sup>6</sup> Southall, B. L., D. Moretti, B. Abraham, J. Calambokidis, P.L. Tyack. In review. Marine Mammal Behavioral Response Studies in Southern California: Advances in Technology and Experimental Methods. Marine Technology Society Journal.



## SOCAL-11 PROJECT REPORT

(“pre-exposure”) period. Given that specific criteria were met regarding the operational area (described below), specific and controlled sound “exposure” sequences (using the simulated mid-frequency military sonar and noise control signals described below) were initiated using explicit transmission and monitoring/safety shut-down protocols (also see below). Following the cessation of sound transmissions, monitoring was sustained during a “post-exposure” period. The pre-exposure period served as the control comparison for responses in the exposure phase. If conditions arose when animals were tagged but we were unable to proceed with a CEE because protocol conditions were not met (*e.g.*, presence of neonate animals that would be exposed), a full control sequence would have been conducted with a baseline period, a “mock” exposure (source deployed but not transmitting), and a “post-exposure” sequence. This occurred twice in SOCAL-10, but did not occur in SOCAL-11 and all 13 CEE sequences included sound transmissions in the exposure phase. In SOCAL-10 on several occasions multiple CEEs were conducted within the same day on different groups of animals with the condition that the sound source had to be at least 10nm away from the earlier location for a second experiment. This was not done in SOCAL-11 – all CEEs took place on different days.



The SOCAL-BRS sound source was custom-built for this project, with the primary goal of reducing the size of both the transducer and the dry-side electronics from previous project. The source could transmit mid-frequency signals at relatively high output levels while running off the ship’s AC power supply. It consisted of a 15-element vertical line-array of individual ceramic disk-shaped transducers powered individually and controlled to form a single output beam. This source was tested before

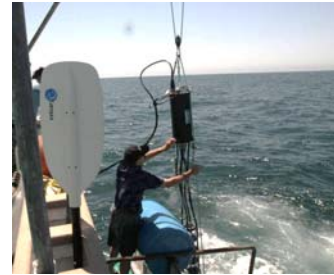

and used successfully during SOCAL-10 and again in SOCAL-11. In general it has performed exceptionally well and met the stated objectives of generating fairly loud, highly calibrated and precise, repeated mid-frequency sounds from in a very compact package that was easily deployed and retrieved by hand. Its small dry-side footprint enabled it to be operated from the relatively small *R/V Truth* using just ships power. In SOCAL-10 some problems were encountered in the temporal spacing of transmission sequences due to software control errors, resulting in some deviation from the planned 25s duty cycle. These problems and several other minor issues were rectified prior to SOCAL-11 and the source was again tested and calibrated both at Dodge Pond (see Appendix I) and in the field prior to experimental CEEs to validate performance was within specifications. The source performed flawlessly in SOCAL-11 for all CEE sequences, meeting all specifications for output levels in the ramp-up and full power phases, timing of output signals, and rapid shut-down of transmissions when safety protocols required this.

## SOCAL-11 PROJECT REPORT

As in SOCAL-10, two sound types were transmitted during CEEs in SOCAL-11. Because a primary objective was to provide information relevant to the potential effects of military sonar on marine mammals, a simulated mid-frequency active (MFA) sonar signal was used. This signal was designed to be similar to the general category of transmit waveforms used in SQS-53C tactical sonars by the U.S. Navy and other nations. However, it is best described as a simulated MFA signal because, while features of the waveform were specifically designed to mimic the signals used in these systems, the maximum output levels were much lower (~25 dB) than real sonars, as well as other important differences. For instance, the single SOCAL-11 sound source was stationary whereas Navy sonar operations involve mobile sources, sometimes operating in groups and at relatively high speeds. Additionally, transmissions lasted a maximum of 30 min total whereas Navy sources may operate for considerably longer and cover much larger areas.

The MFA signal had a 0.5s linear frequency modulated upswEEP from 3.5 to 3.6 kHz, a 0.5s constant frequency tone at 3.7 kHz, a 0.1s silent interval, and a 0.3s constant frequency tone at 3.9 kHz. Thus the total duration of the MFA signal was 1.4s and sounds were nominally transmitted once every 25s (to mimic the output characteristics typical of many 53C systems) beginning at a broadband source level of 160 dB re: 1 $\mu$ Pa (RMS) ramping up 3 dB per transmission to a maximum transmitted source level of 210 dB re: 1 $\mu$ Pa. This resulted in a maximum of 72 total signals, just over one minute of total output energy per CEE sequence.

The pseudo-random noise (PRN) stimulus was made up of a 1 sec signal of noise in the 3.5 to 3.9 kHz frequency band, followed by a 0.1 sec silent interval, followed by a 0.3 sec signal of noise in the 3.5 to 3.9 kHz frequency band. Like the MFA stimulus, the PRN signal lasted for an total duration of 1.4 sec and was repeated every 25 sec, ramping up 3 dB per transmission from 160 dB re: 1 $\mu$ Pa to the maximum output source level (which was 206 dB re: 1 $\mu$ Pa for this sound type). The total maximum transmission time was 30 min (*i.e.*, 72 total signals maximum or just over one minute of total output energy per CEE sequence).

### *Specific CEE Protocols and Shut-Down Criteria*

The specific protocols for conducting CEEs in SOCAL-11 are described below, including conditions required to begin, continue/terminate, and monitor the experimental area following CEEs. The following conditions were required to be met prior to CEEs:

- Tags must be attached for a sufficient duration to reduce attachment disturbance effects and to obtain a reasonable amount of baseline behavioral data (using tags and visual observations). For mysticetes this was a minimum of 45 min and ideally two hours and for odontocetes (and at least one deep foraging dive and complete surface sequence for beaked whales).
- Confirm that *no calves in group are neonates*, as defined within the NMFS scientific

## SOCAL-11 PROJECT REPORT

research permit (presence of fetal folds for non-ESA listed species and <6 months for ESA-listed species).

- Determine that operational conditions (*e.g.*, weather, location of non-SOCAL-BRS vessels) are likely to allow for successful completion of CEE and interpretation of results, as well as post-exposure monitoring.
- Determine that the sound source is not within 1nm of any landmass or within 3nm from land within the Channel Islands National Marine Sanctuary.

Provided that these conditions were met, as agreed upon by the chief scientist and co-investigators in the field, researchers would then proceed with CEEs according to the following procedures:

- Position source vessel ~1000m from the focal group or animal, taking into account group movement/distribution, to extent possible.
- Reduce engine propulsion noise and speed, as much as possible.
- Deploy source to specified depth (~20m).
- Determine no marine mammals within 200m of source vessel.
- Initiate sound transmissions at a source level of 160 dB re: 1 $\mu$ Pa, one transmission every 25s ramped up by 3 dB per transmission to maximum output level.
- Maintain transmissions once each 25s at the maximum source level, unless any contra-indicators require shut-down (see below), for a total maximum transmission time (including ramp-up) of 30 min.
- One exposure type was used per focal individual/group, with sufficient pre-exposure baseline and as much post-exposure “recovery” as possible. A pseudorandom sequence within operational areas was used when CEEs occurred in the same area on sequential days to reduce the potential that prior incidental exposures might affect responses in focal animals.

During CEEs the following safety shut-down protocols were used, any of which resulted in the immediate termination of active sound exposures:

- *Any marine mammal inside 200m shut-down zone* around source vessel during transmissions.
- Visual detection from source boat or RHIBs of either the focal animal(s) or incidentally-exposed marine mammals exhibiting the following behaviors<sup>7</sup>:
  - o *Directed, high speed or other abnormal swimming behavior (at surface), especially toward shore.*

---

<sup>7</sup> None of these behaviors were observed in any CEE sequence during either SOCAL-10 or SOCAL-11

## SOCAL-11 PROJECT REPORT

*o Unusual and abnormal surface/subsurface behavior involving apparent disorientation and confusion or dramatic changes in group cohesion.*

- Controlled sound exposures were conducted with focal groups that include dependent calves that are not neonates (no fetal folds for non-ESA listed species). However, if the *mother-calf pair had become clearly separated during transmissions* (as determined by one of the principal investigators based on the input of trained marine mammal observers) CEEs would have been terminated.
- For beaked whale CEEs we sought to only expose animals during their deep foraging dives by monitoring focal group echolocation clicks, although this was not a mandated requirement and in fact the one SOCAL-11 beaked whale CEE appears to have occurred during a non-foraging dive.

Following CEEs, the following post-exposure monitoring was conducted after sound transmission:

- Either the source boat and/or RHIB visual teams maintain visual (and passive acoustic monitoring (PAM), if applicable/possible) monitoring of focal groups for at least one hour post CEE and VHF radio monitoring for as long as possible;
- Post-CEE visual monitoring of the sound playback area was conducted by both the visual observers on the source vessel and the RHIBs, who maintained focal follow of the tagged animal(s) during the post-exposure period. These observations were maintained within the playback area for a minimum of 45 min and typically longer.

### ***Summary of CEEs Conducted***

During the two experimental legs of SOCAL-11, CEEs were successfully completed with on 18 individuals (affixed with either v.2 or v.3 III Dtags) of three marine mammal species.

<b>Blue Whales: 13</b>	<b>Risso's Dolphin: 4</b>	<b>Cuvier's beaked whale: 1</b>
--------------------------------	-----------------------------------	---

Thirteen complete CEE sequences were conducted, each on different days to complete CEEs on these 18 individuals. The total number of tagged focal animals exceeds the total number of CEE sequences because five of the 13 CEE sequences involved multiple blue whales. On multiple occasions sound transmissions were terminated during CEEs prior to the 30 min. maximum transmission according to specified safety protocols.

## SOCAL-11 PROJECT REPORT

These were due to marine mammals ignoring the sound transmitting at full power and entering the 200m “shut-down” zone around the sound source (*California sea lions*: sequences #2011\_02 and #2011\_07; *Risso’s dolphins*: sequence #2011\_11). On another occasion (#2011\_06), U.S. Navy personnel began conducting a training operation using live dolphins in the same area as CEEs were occurring. They did not respond to radio communication regarding sound transmissions, so the chief scientist called for a shut-down of the CEE even though the animals were not within the specified safety radius.

A chronological list of these CEE sequences by each experimental leg is given below, showing date and CEE number, the sound exposure type and duration, and a brief description of behavioral state of focal animals of different species during CEEs. Additionally, a map showing the location of each CEE by number is also shown for each experimental leg.

### SOCAL-11 Leg I CEE Sequences

DATE (CEE #)	TIME	SPECIES (individ)	CEE TYPE	CEE DURATION	COMMENTS
29 July 11 (#2011_01)	1525-1555	Blue whale (bw11_210a)	MFA-1	30:00	Ziphid-tagged blue whale (Dtag 224); good full sequence after repositioning several times; deep feeding mode
29 July 11 (#2011_01)	1525-1555	Blue whale (bw11_210b)	MFA-1	30:00	Same sequence as above. This Physalus-tagged whale (Dtag 236) was in the same aggregation as the Ziphid-tagged one, but no dives deeper than 15m
30 July 11 (#2011_02)	1108-1126 (44 pings)	Blue whale (bw11_211a)	PRN-1	18:00	Single blue whale tagged by Ziphid twice – one tag stuck but slid and was not transmitting right; CEE interrupted by sea lions. Animal in deep feeding mode
1 Aug 11 (#2011_03)	1246-1316	Blue whale (bw11_213b)	MFA-1	30:00	Single blue whale CEE (another tagged earlier but came off); in a moderate aggregation. Good full sequence after repositioning several times. Animal apparently in relatively deep feeding mode
2 Aug 11 (#2011_04)	1120-1150	Blue whale (bw11_214b)	PRN-1	30:00	Good CEE on this trail animal in a group of two (other tagged with v3). Was switching between patches – in surface lunge feeding at time of CEE.
2 Aug 11 (#2011_04)	1120-1150	Blue whale (bw11_214c)	PRN-1	5:00	First Dtag III deployment on a mysticete just ahead of the CEE and with sufficient baseline, but tag fell off 5 minutes into CEE. Shallow surface lunge feeding mode
4 Aug 11 (#2011_05)	1346-1416	Risso’s dolphin (gg11_215a)	MFA-1	30:00	First Dtag III deployment on a Risso’s dolphin. Good focal follow, full CEE at about 2000m and solid baseline as animals went to deep foraging mode

# SOCAL-11 PROJECT REPORT

## SOCAL-11 Leg I CEE Sequences (cont.)

DATE (CEE #)	TIME	SPECIES (individ)	CEE TYPE	CEE DURATION	COMMENTS
6 Aug 11 (#2011_06)	1749-1802	Blue whale (bw11_218a)	PRN-1	23:00	Ziphid attached Dtag to deep feeding blue whale that took off before we started and headed south. Was 4nm or more during CEE and in traveling mode during CEE. Shutdown by Navy dolphins in general area.
6 Aug 11 (#2011_06)	1749-1802	Blue whale (bw11_218b)	PRN-1	23:00	Physalus attached Dtag to deep feeding blue whale in same group as 218a. Wound up being the focal whale during CEE. Shutdown by Navy dolphins
7 Aug 11 (#2011_07)	1558-1622	Blue whale (bw11_219b)	MFA-1	24:00	Ziphid attached Dtag to deep feeding blue whale in very deep water – almost certainly same animal as 219a which came off earlier. Animals doing relatively long dives in deep water. Shutdown by Cal sea lion
8 Aug 11 (#2011_08)	1549-1619	Blue whale (bw11_220a)	MFA-1	30:00	Ziphid tagged a blue feeding in deep water (~1000m) earlier in the day; still had tag on for CEE but was ~5nm away.
8 Aug 11 (#2011_08)	1549-1619	Blue whale (bw11_220b)	MFA-1	30:00	Went to this second whale later when looking for beaked whales and focal on it. Good full CEE; animal moving away during CEE.
9 Aug 11 (#2011_09)	1459-1529	Blue whale (bw11_221a)	PRN-1	30:00	First animal tagged by Ziphid was lead animal in a pair. Good full CEE; animals remaining in area.
9 Aug 11 (#2011_09)	1459-1529	Blue whale (bw11_221b)	PRN-1	30:00	Second animal tagged by Ziphid was trail animal in a pair. Good full CEE; animals remaining in area.

## Locations of all SOCAL-11 Leg I CEE Sequences

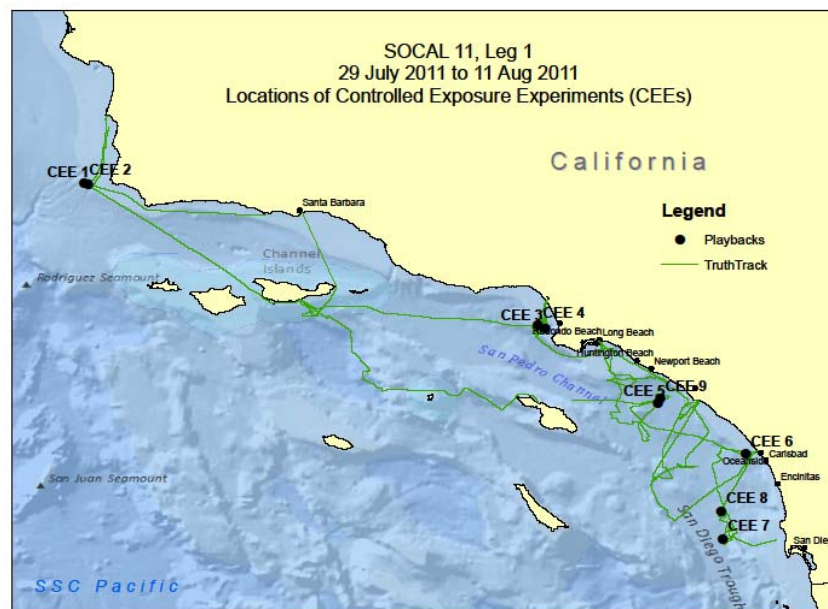

## SOCAL-11 PROJECT REPORT

### SOCAL-11 Leg II CEE Sequences

DATE (CEE #)	TIME	SPECIES (individ)	CEE TYPE	CEE DURATION	COMMENTS
21 Sept 11 (#2011_10)	1223-1253	Risso's dolphin (gg11_264a)	MFA-1	30:00	Great tag attachment and textbook deployment on a Risso's dolphin; group moved away after 700m CPA
22 Sept 11 (#2011_11)	1527-1542	Risso's dolphin (gg11_265a)	PRN-1	15:00	Dtag III on a Risso's dolphin and playback later in the day. Had a shutdown because of other dolphins in the group within 200m shutdown zone.
24 Sept 11 (#2011_12)	1805-1835	Cuvier's beaked whale (zc11_267a)	MFA-1	30:00	Ziphius in a group of as many as 8 tagged and tracked for 10+ hours. Not entirely sure that CEE was on deep dive, but some echolocation clicks detected – other groups were in the area but all according to protocols
26 Sept 11 (#2011_13)	1507-1537	Risso's dolphin (gg11_269a)	MFA-1	30:00	Ziphiid got a solid v3 Dtag on a Risso's mid-day and we tracked it toward Catalina and did a solid 30 min CEE with no issues – good range and orientation

### Locations of all SOCAL-11 Leg II CEE Sequences

## SOCAL-11 PROJECT REPORT

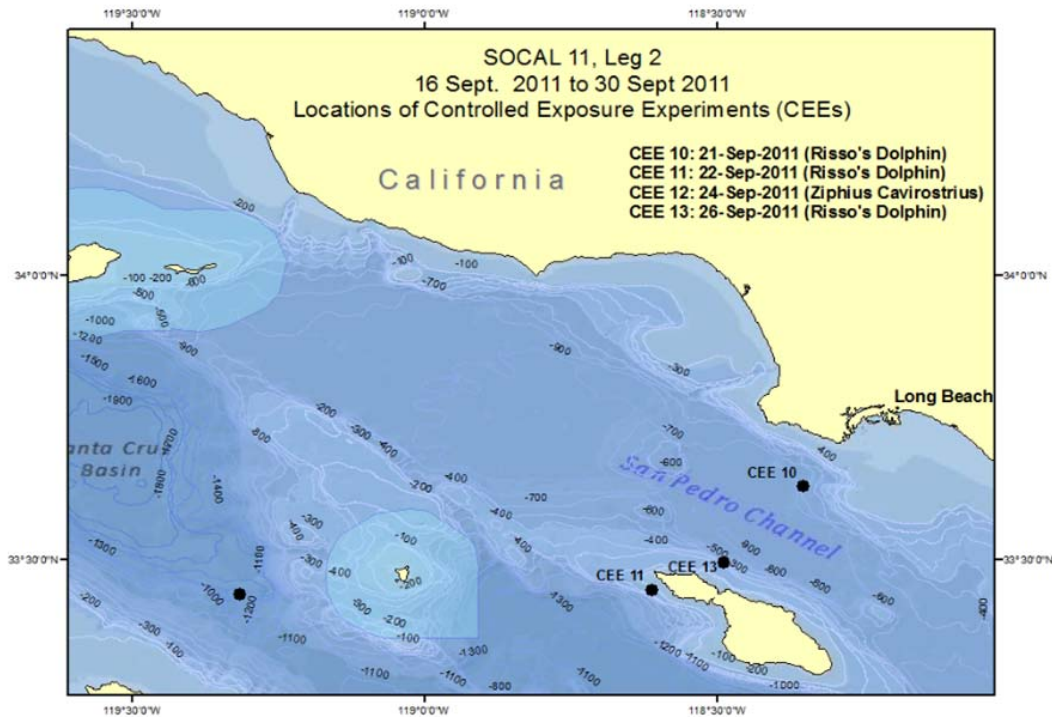

### ***CEE Summary by species***

A summary of the CEEs conducted by species as well as a general consideration of the preliminary observations of behavioral responses is given below. Detailed analysis of movement, diving, vocal, and other behaviors in the “baseline”, “exposure”, and “post-exposure” phases of CEEs are currently being conducted to assess the specific responses to sounds of each type in relation to baseline behavioral conditions. The following observations should be considered preliminary based on clear differences in behavior from visual monitoring and/or initial analysis of the tag data; additional or different subtle responses may be revealed by the more detailed behavioral assessments that are currently ongoing.

### **Blue whales**

The largest number of CEEs in SOCAL-11 was conducted on blue whales (n=13). With the 19 CEEs on blue whales in SOCAL-10, we have conducted a total of 32 CEEs on this species in the first two years of SOCAL-BRS. Of the 13 blue whale CEEs in SOCAL-11, seven involved the MFA sound type and six used PRN. For each sound type, some exposures were conducted when animals were in a surface travel/feeding (~50m or less) and/or socializing behavioral state and others while animals were in a deep feeding (>50 m) and/or traveling mode (see table below).



SOCAL-11 PROJECT REPORT

Species	Exposure Type	N	Behavioral State Breakdown
BLUE WHALE	MFA-1	7	Surface travel/shallow feeding: n = 2 Deep feeding: n = 5
BLUE WHALE	PRN-1	6	Surface travel/shallow feeding: n = 3 Deep feeding: n = 3
BLUE WHALE	TOTAL	13	TOTAL - ALL SEQUENCES

All CEE transmissions were detected on the acoustic tags for all animals and received sound levels during CEE sequences were within the target range for this experiment, ranging from ambient levels to about 160 dB re: 1 $\mu$ Pa. In cases where two animals were tagged, one of the RHIBs would remain with each focal while but the central research vessel would position the sound source at a range of ~1000m from one of the focal animals. In these cases, some tagged animals were several nm from the sound source during transmissions and received considerably lower RLs accordingly.

For many of the CEE transmissions of either sound type, there were few obvious behavioral responses detected either by the visual observers or on preliminary analysis of the tag data. An example of this can be seen in some of the preliminary summary dive and movement profiles for blue whale subject bw11\_214b who was one of the focal animals included in CEE #2011\_004 on 2 August 2011. A dive profile of a blue whale showing received sound levels from the PRN playback ranging from under 100 to about 150 dB re: 1 $\mu$ Pa can be seen below. The animal maintained a similar dive pattern of about 50m or less with a few deeper excursions throughout the sound exposure.

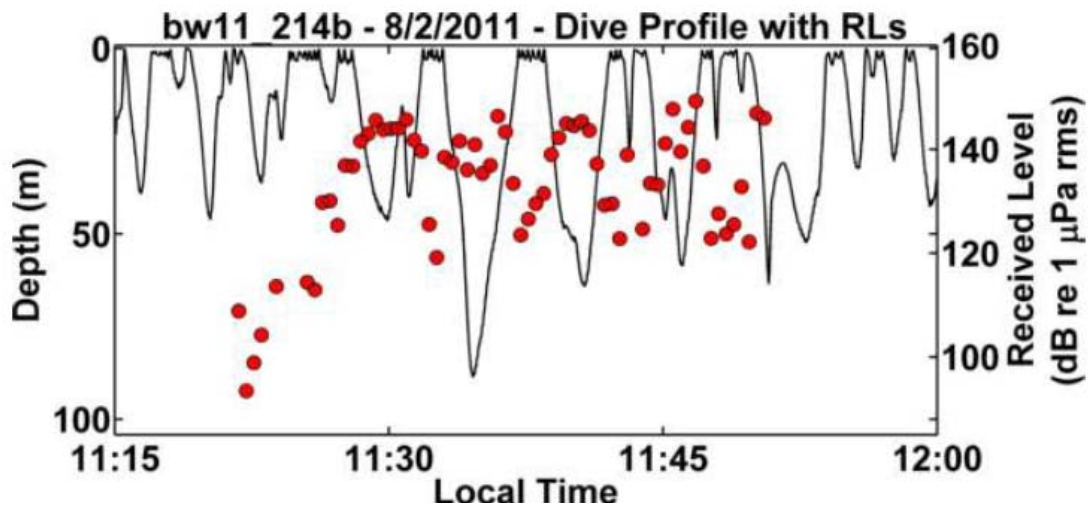

## SOCAL-11 PROJECT REPORT

Taking a birds-eye view of the uncorrected “pseudotrack” which is the approximate relative geographic location of the whale (which is later corrected and refined based on visual detections at specific GPS points), it also appears that there is no clearly obvious difference in the movement patterns of the whale during or following sound exposure. Rather, its movements appear to largely continue on a circuitous track consistent with searching for and exploiting near-surface prey patches in which it was feeding.

**bw11\_214b - 8/2/2011 - Uncorrected Pseudotrack**

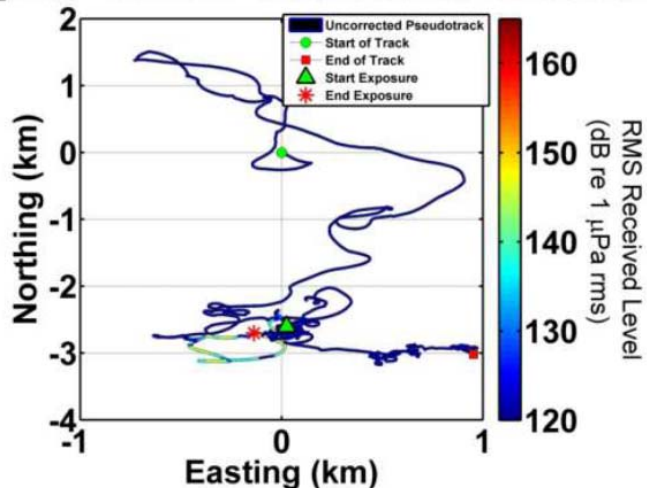

In other cases, behavioral changes did appear to occur, consisting primarily of small changes in dive behavior and general avoidance of the sound source that was relatively mild and temporary. Behavior appeared to return to baseline conditions shortly after the cessation of CEEs, at least based on the preliminary assessments. An example of this can be seen in some of the preliminary summary dive and movement profiles for blue whale subject bw11\_220b who was one of the focal animals included in CEE #2011\_008 on 8 August 2011. A dive profile of a blue whale showing received sound levels from the MFA playback ranging from under 100 to about 135 dB re: 1 $\mu$ Pa can be seen below. As can be seen, this animal was diving consistently to over 200m, but during the onset of the sound exposure exhibited a slightly different kind of dive followed by a slightly longer surface interval and then a switch to generally shallower dives. It is certainly possible that the animal was merely switching to a different prey layer in this case (and the integration of prey data in some of the SOCAL-11 CEEs will help to address this issue), but it is notable that this change occurred at the same time interval as the onset of sound exposure.

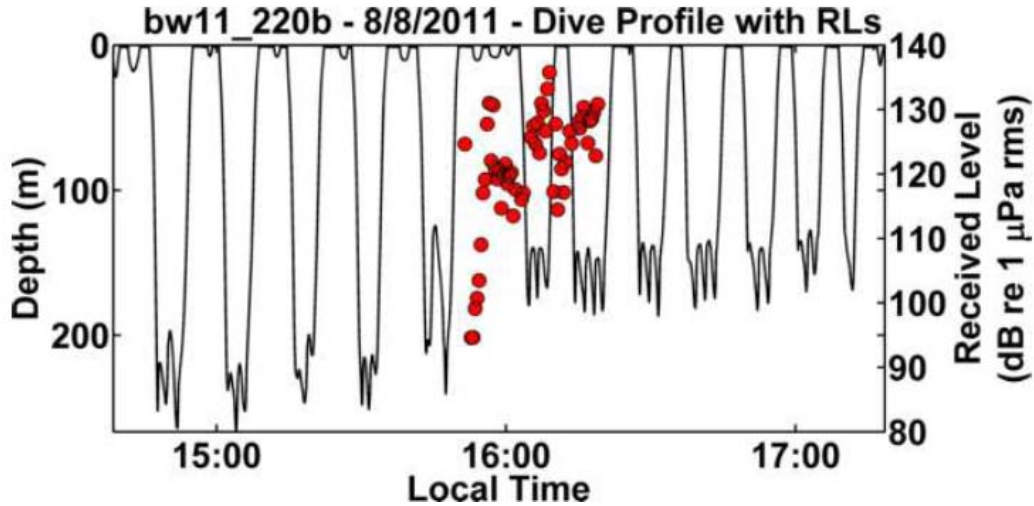

Additionally, as seen in the uncorrected pseudotrack of this whale on the following page, the onset of sound exposure was associated with a directed movement of the whale over several km; this directed movement was away from the location of the sound source. Again, it is noted that there are other directional movements of the whale during this observation interval, but this straight line course away from the sound source associated with an apparent change in diving behavior was closely associated in time with the onset of MFA exposure at relatively low levels.

**bw11\_220b - 8/8/2011 - Uncorrected Pseudotrack**

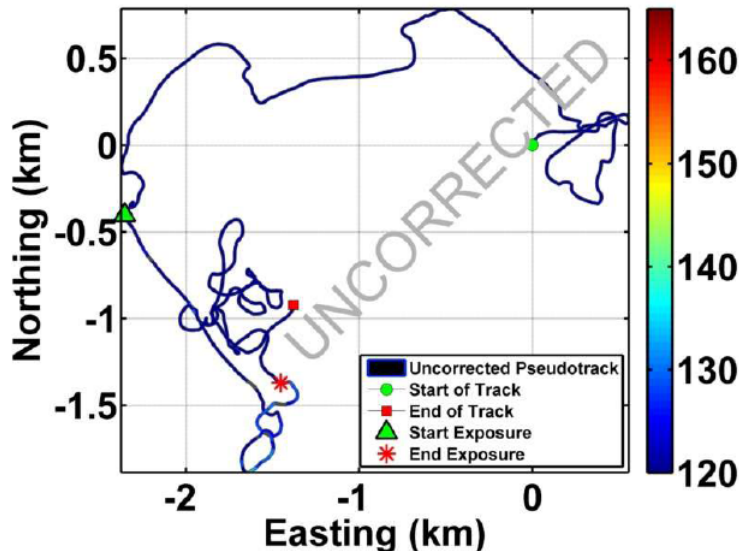

While it should be emphasized that these observations are preliminary and that detailed analyses are underway, the general pattern in SOCAL-11 for blue whales appeared to be fairly similar to that seen in SOCAL-10. In many cases, no clear changes in behavior seemed to occur even in when exposure levels were relatively high. In other cases,

## SOCAL-11 PROJECT REPORT

minor changes in diving and temporary avoidance behavior seemed evident, often beginning at quite low received levels. Furthermore, responses appeared to relate more to the behavioral state of the animals (e.g., surface feeding vs. deep feeding/travel) during exposure than the specific sound exposure type or the received level of sound.

### Risso's dolphin

Building on the first successful tag attachments in 2010, SOCAL-11 had considerable success with Risso's dolphins in terms of tagging and CEEs. Seven individuals were tagged (six with suction cup acoustic tags) and four CEEs were conducted (three MFA and one PRN). As seen in the table below, most of these occurred in conditions where animals were in surface travel or relatively shallow diving mode; one CEE involved animals that had gone into a slightly deeper diving mode.

RISSOS DOLPHIN	MFA-1	3	Surface travel/shallow feeding: n = 2 Deep feeding: n = 1
RISSOS DOLPHIN	PRN-1	1	Surface travel/shallow feeding: n = 1 Deep feeding: n = 0
RISSOS DOLPHIN	TOTAL	4	TOTAL - ALL SEQUENCES

Field observations and initial analysis of the Risso's CEEs failed to reveal clear behavioral responses. Below is an example of a dive profile with received CEE sounds for an individual (gg11\_264a) involved in CEE # 2011\_010 on 21 September 2011. As seen in the tracks, the animal (and the rest of the group of several dozen animals) was essentially at the surface during the CEE and maintained essentially the same behavioral patterns. The group transitioned into much deeper foraging dives later in the late afternoon, several hours after the CEE.

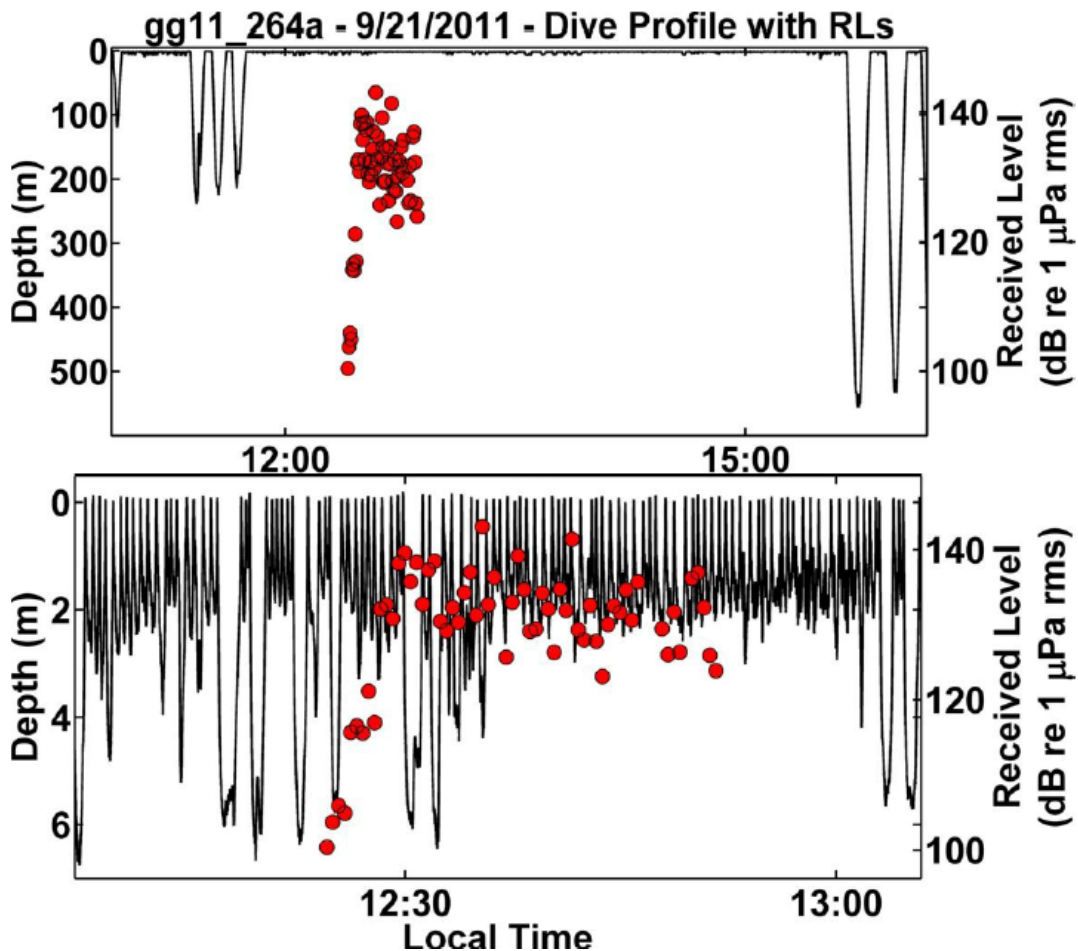

The above example is typical of the time of day, behavioral state, and CEE results to date from the five CEEs on Risso's dolphins obtained in the first two years of SOCAL-BRS. As discussed below, additional Risso's CEEs are required to adequately describe behavioral responses in these animals. Subsequent CEEs will focus on additional behavioral states, including deeper foraging modes.

#### Cuvier's beaked whale

As in SOCAL-10, there was one successful tag attachment and CEE on an adult Cuvier's beaked whale (almost certainly female but possibly a sub-adult male) in SOCAL-11. Given the extremely calm conditions required to locate and track these animals for the many hours required to complete the protocols specified, this rate of success on this species is probably as or even better than expected. These two accomplishments in SOCAL-BRS remain the only fine-scale resolution diving and broadband acoustic data on this species in the Pacific Ocean and the only CEEs of any type conducted on this species, which is the most prevalent species in known marine mammal strandings

## SOCAL-11 PROJECT REPORT

associated with the use of mid-frequency military sonar systems.

The individual involved in SOCAL-11 was in a social group of at least five individuals that were diving roughly synchronously, within a larger group of as many as 8-10 beaked whales in the same general area to the west of Santa Barbara Island in the southern part of the Santa Cruz Basin. Ideal offshore conditions persisted for almost the entire day, but operations were conducted outside of the SCORE range because other activities were ongoing there. This group of animals was detected by the *Truth* visual observer in quite shallow water for this species (<500m) to the west of Santa Barbara Island and then tracked northwest into deeper water. The *Truth* vectored in both RHIBs and within several hours a v3 Dtag was successfully attached to one animal. This group was visually monitored during their brief periods at the surface from both the RHIBs and the *Truth* visual observers and were acoustically monitored during the “baseline” deep foraging dive that occurred around midday by the towed array system on the remote PAM vessel (results communicated to the *Truth*) and from sonobuoys deployed and monitored on the *Truth*. The group was successfully tracked during this deep dive acoustically and re-acquired on the surface and continued to be tracked over a number of shallow dives during the afternoon. Later in the day the group appeared to split up and some animals may have gone into deep foraging dives as scattered echolocation clicks were detected. However, there were other cetaceans in the general area as well (common dolphins) and there was ambiguity as to whether the focal group had indeed initiated a deep foraging dive. In accordance with specified protocols stating that CEEs would focus on deep dives but did not require certainty, a CEE using simulated MFA sonar was initiated. As can be seen in the figure on the following page, it appears that in fact this was not a typical deep foraging dive, but that the animal was conducting another shallow dive. Just after the onset of transmissions, the animal appears to have changed direction and dove to over 1000m. This pattern is quite unusual for this species from what is known from the baseline shallow dives in this and the SOCAL-10 individual, as well as the larger body of data from Cuvier’s beaked whales tagged with DTags in the Mediterranean Sea. After the CEE began, the group was not sighted again; the tag was recovered ~20km away the following morning (in the general direction of travel prior to the CEE).

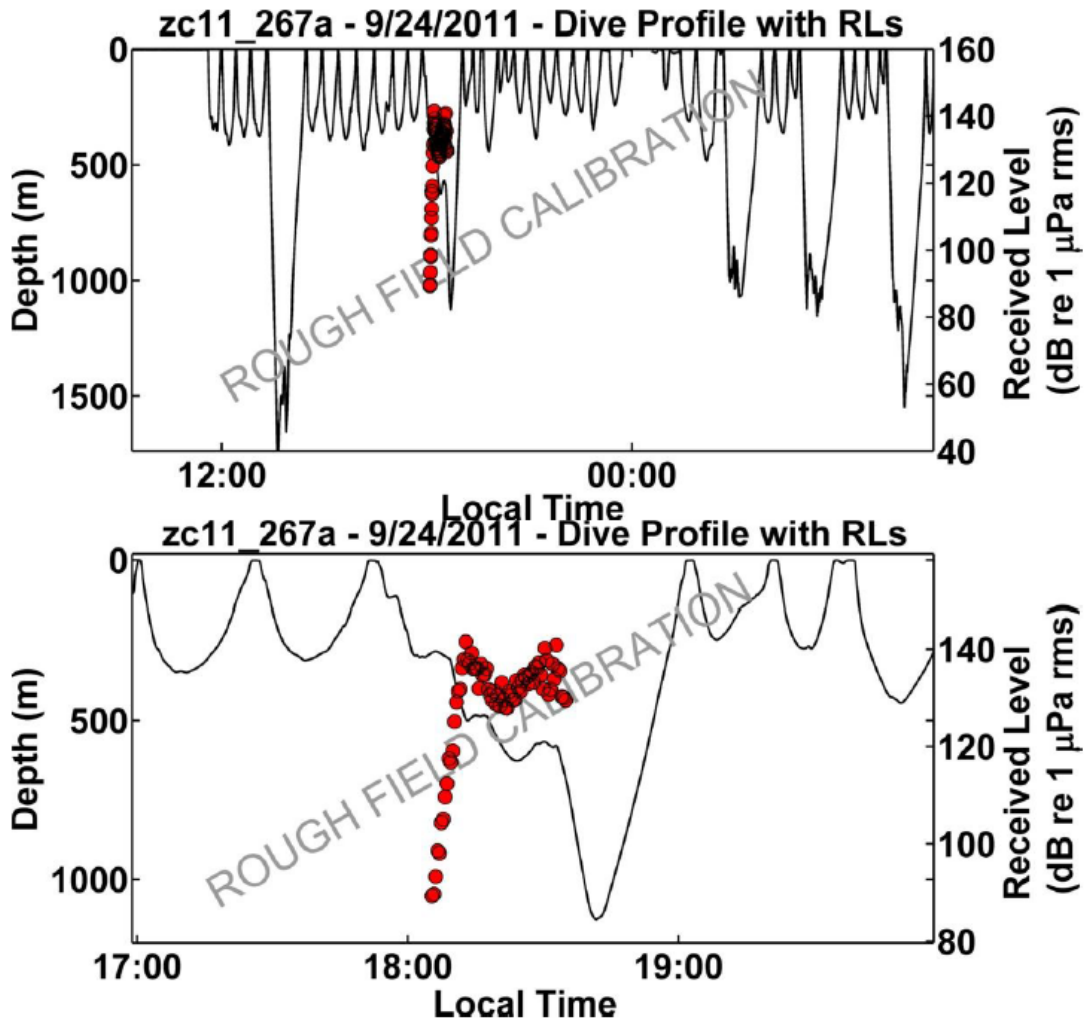

It should be noted that subsequent analyses of these data in combination with the SOCAL-10 beaked whale CEE are underway and the figures shown here represent preliminary results and rough field calibrations; subsequent analyses of the v3 Dtag data may result in slightly different calibrated RLs. Based on the preliminary analyses, received MFA signals on the whale throughout this CEE sequence ranged from just above ambient noise to about 135-140 dB re: 1 $\mu$ Pa. (signal-to-noise ratios on the order of 40 dB). However, from the preliminary analysis it appears that this subject clearly had a strong behavioral response to the MFA CEE and that this response was initiated quite early in the playback when received sound levels were quite low ( $\sim$ 100 dB re: 1 $\mu$ Pa). While the conditions of this playback differ from SOCAL-10 (apparently on a shallow dive rather than a deep foraging dive), the results appear to be generally similar in suggesting a strong response to CEEs at low RLs. These results are generally consistent with those from CEEs with Blainville's beaked whales in the Bahamas BRS projects in suggesting beaked whales are particularly sensitive to sound, with the observation that the Cuvier's beaked whale responses seem to occur at even lower RLs.

## 8. OVERALL ASSESSMENT: ACCOMPLISHMENTS VS. OBJECTIVES

The following is a simple assessment of the specified objectives for SOCAL-11 relative to the accomplishments realized in the field. Nearly all objectives were achieved, with expectations exceeded in most regards.

(1) *Obtain baseline behavioral data.*

**Objective fully achieved.** A total of 38 tags of 4 types were deployed on 35 individuals of four different marine mammal species. This resulted in nearly 200 hours of acoustic and movement data on tags, which was accompanied by several times as much data in dedicated focal follows. Additionally, thousands of marine mammal visual detections were made in various areas throughout southern California and hundreds of photo IDs were obtained. Each of these data sources will contribute to the basic understanding of the species being studied. Of particular note is the substantial amount of baseline diving and acoustic behavior of Risso's dolphins. Quite little is known about these behavioral patterns in this species and the ongoing baseline behavioral assessment being conducted using these data will be imperative for deriving an analytical methodology for assessing CEE responses.

(2) *Conduct controlled exposure experiments (CEEs) on baleen whales, beaked whales, and Risso's dolphins.*

2a) Species focus to remain flexible based on conditions encountered, but emphasis on baleen whales, beaked whales, and Risso's dolphins

- **Objective fully achieved.** Thirteen CEE sequences were conducted on 18 individuals of three marine mammal species using two different sound types (MFA and PRN). The Cuvier's beaked whale CEE is just the second ever conducted in this important species (the first being in SOCAL-10) and the Risso's dolphin CEEs quadrupled the sample size on this species in terms of responses to mid-frequency sounds in CEEs. The large number of CEEs on blue whales largely rounds out the SOCAL-BRS effort on this species by adding more samples in deeper water areas and behavioral modes, and gives us a larger sample size on known individuals for this previously untested species (to MF sources including simulated Navy sonar) than currently exists for CEEs in any other marine mammal species.

2b) Derivation and application of "tagless" playback approaches a priority for SOCAL-11 (target species: Risso's dolphin)

- **Objective partially achieved.** Considerable progress was made in adapting the group sampling protocols used on smaller cetaceans in other areas to the SOCAL-BRS configuration and data collection



## SOCAL-11 PROJECT REPORT

protocols using WILD. Dedicated group follows of non-tagged delphinids were conducted on multiple days, resulting in a large number of lessons-learned. However, this proved perhaps more challenging than expected and clearly these tagless playbacks will be feasible in a relatively narrow set of conditions. Following the test focal follows and modifications to the tagless CEE protocols, these conditions did not present themselves and there were not dedicated CEEs conducted on groups of animals without tags in SOCAL-11.

(3) *Test optimal configuration for subsequent studies, which may include realistic/actual military sources*

- **Objective fully achieved.** This is somewhat difficult to assess, given the uncertainties of the exact configuration and operational protocols for CEEs involving real Naval operations. However, SOCAL-11 was operated entirely off the *R/V Truth* and confirmed the decisions made following SOCAL-10 of working with smaller, more agile research platforms and teams to ensure flexibility in working on the suite of species off southern California. Additionally, the modification to conducting dedicated focal follows of animals from the RHIBs rather than the central research platform provides a greater autonomy of operation that will facilitate a leaner mode of operation. This is expected to evolve into smaller shore-based teams operating from even smaller overall platforms and agile tagging and focal follow teams to operate in conjunction with Navy sources serving as experimental sound sources in future studies.

(4) *Obtain data to support the Navy's SOCAL range monitoring*

- **Objective fully achieved.** A large biological dataset on southern California marine mammals was obtained through SOCAL-11. We accomplished thousands of sightings of at least 15 marine mammal species, hundreds of photo IDs of known and new individuals, and collected biopsy and skin samples from numerous species. These data will be available for use and integration into the range monitoring efforts underway in the general SOCAL area.

## 9. SOCAL-10 TRANSPARENCY AND PUBLIC IMPACT

The scientific data generated by SOCAL-BRS will contribute to a greater understanding of biologically important areas in southern California, as well as how marine mammals dive, communicate, and respond behaviorally to different sounds. Preliminary data from the first two seasons have been presented and discussed with various scientific, educational, government, and conservation organizations to increase public awareness and appreciation of these valuable areas and species. The SOCAL-BRS project is and will

## SOCAL-11 PROJECT REPORT

remain committed to openness and transparency of the project and to the timely and effective transmission of results. Efforts before, during, and following SOCAL-11 clearly demonstrated this commitment.

There were numerous open discussions in over a dozen public meetings, exchanges of questions and responses through the project website [www.socal-brs.org](http://www.socal-brs.org) and from-the-field blog, and other interactions both public and personal with conservation interests and other scientists. This is a process that will continue throughout the SOCAL-BRS project. Additionally, the first results from SOCAL-10 began to be presented and discussed within the scientific community at a number of meetings, most notably with a number of presentations at the 16<sup>th</sup> Biennial Conference on the Biology of Marine Mammals in Tampa, FL in December 2011. Finally, at that meeting and subsequently, researchers from the SOCAL-BRS team have increasingly been collaborating with scientists and statisticians working on other BRS projects around the world in terms of data analysis, integration, and communication of results to the scientific, public, and regulatory communities. As additional analyses are conducted, the results will continue to be integrated with ongoing, international efforts to better understand behavioral responses of marine mammals to sound. The SOCAL-BRS data will continue to be made available through scientific presentations and publications in a timely manner, as well as through various other public outlets to maximize their utility and impact.

## 10. CONCLUSIONS AND NEXT STEPS

### *Overarching conclusions from SOCAL-11*

#### **1. *Modification of the overall configuration and to operational protocols for SOCAL-11 was successful***

- SOCAL-11 was again quite productive with a smaller primary research vessel and overall configuration in terms of total number of tags, species, and CEEs completed in a variety of near-shore and offshore areas
- Moving to conducting essentially all dedicated focal individual follow protocols from the RHIBs was a substantial improvement in terms of data collection, integration, and analysis
- Applications of group follow protocols for sampling behavioral responses of non-tagged animals show some promise, albeit in a relatively narrow range of operational conditions and species.
- Additional refinements will be made, moving toward the objective of including real operations in a CEE configuration in later years.
- A significant amount of data on prey distribution and density estimates were obtained in SOCAL-11, some outside the CEE context and some in areas where tagged blue whales were feeding before, during, and after CEEs.

## SOCAL-11 PROJECT REPORT

### 2. **CEE protocols and safety measures apparently worked well**

- Useful behavioral response data were obtained and included clear responses in some conditions, but in no cases were animals harmed or responded in extreme ways outside those anticipated and planned for within the protocols
- In cases where marine mammals of either the focal species group or incidentally in the area during CEES came within the specified safety radii, sound source shut-downs were executed immediately.
- Through coordination with the Southwest Marine Mammal Stranding Network, SOCAL-11 maintained current information on any marine mammal strandings that might have occurred. There were no live cetacean strandings in southern California reported during the experimental legs of SOCAL-11 or within several weeks following. A single live bottlenose dolphin stranded in San Francisco Bay on 3 October – this was during the second leg of SOCAL-11 but several hundred miles away.

### 3. **Preliminary results of SOCAL-11 suggest a lack of clear behavioral responses in many conditions and temporary changes in behavior in certain other conditions**

- A second beaked whale CEE was conducted in SOCAL-11 that indicates a similar relatively strong response at low RL as was observed in SOCAL-10
- Risso's dolphin CEES were limited in terms of the times of day and behavioral conditions in which they occurred, but suggest relatively minor if any responses in these conditions.
- Blue whale responses were apparently absent or involved minor changes in diving and movement behavior that returned rapidly to baseline. Differential responses appeared more related to behavioral state than sound type or RL.
- These observations point to a more complex, species- and/or context-specific type of response to these mid-frequency sound sources.

#### *SOCAL-BRS next steps*

The overall SOCAL-BRS effort is planned to occur from 2010-2015, with SOCAL-12 being the third field season. This is expected to be in some ways a transition year, albeit within a generally similar configuration as SOCAL-11. The following are the current understanding of planned next steps for SOCAL-12 and beyond:

- While planning for the SOCAL-12 field season, substantial ongoing effort in analysis, presentation, and publication of the SOCAL-10 and -11 data are well underway. The blue whale and beaked whale CEE analyses are furthest along at this stage, and a collaborative, multidisciplinary team is working on the baseline acoustic and movement behavior of Risso's dolphin.
- The R/V *Truth* will again be used as the primary research platform and sound

## SOCAL-11 PROJECT REPORT

source vessel for two experimental legs in the July-October 2012 time window and operations are expected to occur in similar general areas as in the first two field seasons; precisely where and on which species will depend on environmental conditions and on the distribution of animals.

- Pending permit approval, minke whales, humpback whales, and killer whales will be added as potential focal species for subsequent CEEs.
- SOCAL-12 is expected to again include a dedicated research platform for passive acoustic monitoring (PAM) for the detection of odontocete cetaceans (primarily beaked whales) in areas outside of the SCORE range for at least one of these experimental legs.
- SOCAL-12 will again include integrated prey measurements using scientific echosounders with tagged whale foraging behavior at fine scales for at least one experimental leg.
- Finally, an even smaller and more portable sound source is being developed for SOCAL-12. This source will be field tested in the context of the two experimental legs using the Truth in preparation for a possible third pilot leg based off San Clemente Island. This pilot effort would involve a much smaller field team using one tagging and focal-follow RHIB operating with a smaller, faster sound source vessel.
- Many of the above efforts are in general preparation for SOCAL-13 to -15 efforts that are currently envisioned to include a combined approach with small vessels using similar deployed sources and, as possible, realistic military sources within the context of CEEs to measure responses in scenarios that are as realistic as possible.

**APPENDIX I. Sound Source Testing and Verification**

**Dodge Pond Source Test Summary**

**20 July, 2011**

**POC:**

**David Moretti**

**NUWC**

**Newport, RI 02879**

**[David.moretti@navy.mil](mailto:David.moretti@navy.mil)**

**401-832-5749**

## SOCAL-11 PROJECT REPORT

### Overview

The Lightweight High-Power Acoustic Source System is a relatively lightweight, portable system for transmitting underwater acoustic signals in support of experiments such as the SOCAL-10 and SOCAL-11 marine mammal exposure studies where minimal deployment time is critical. The source was designed by Applied Physical Sciences Inc. in Groton, CT. The system consists of an in-water transducer array and a shipboard amplifier and control unit. The acoustic transducer array consists of 15 flexural disk transducers with 6" center-to-center spacing connected via a flexible wire rope harness to a pressure vessel. The pressure vessel contains 15 tuning inductors (one for each transducer), a depth/pressure sensor, and a compass module that measures heading, pitch, roll, and temperature (of the circuit board; not the water). A Kevlar-reinforced riser cable sends high-voltage (e.g. 200VAC) signals to the transducers and also supplies power for the compass and depth sensors and transmits RS-485 signals from the compass to the topside computer.

### Refurbishment

The source was refurbished in preparation for the SOCAL-11 experiment scheduled to begin on July 29, 2011. All amplifier modules were updated to include changes made on replacement amplifiers during the SOCAL-10 experiment. The Digital to Analog (D/A) converter board was replaced to fix the timing irregularity experienced in 2010. The compass was replaced and the nearby inductors were shielded to prevent interference with the unit. The underwater electronics vessel was refurbished to remove corrosion around connectors. The amplifier drawers were rewired to make field removal and replacement of faulty amplifiers significantly simpler. The transducer cables were replaced and the elements adjusted to the correct 6 inch spacing and fixed in position with clamps which replaced previous stops which utilized set-screws.



**Figure 1. Array suspended over Dodge Pond test enclosure**

SOCAL-11 PROJECT REPORT

**Dodge Pond Test Results**

The array was tested and calibrated at Dodge Pond over 3 days (11, 18, 20 July, 2011). Each element was calibrated and adjusted to maximize its output at its resonant frequency of 3.8 kHz. The maximum 15 element output level of 210 dBre $\mu$ Pa @ 1m was also measured. These results are provided below (Table 1). Note, good agreement was found between the measured 210.3 dB combined output and the calculated output, 210.5 dB based on the measured values of individual elements. These levels were in good agreement with those measured in 2010).

Element Number	Radius from Centerline (ft)	Range to H52 (ft)	Range to H52 (m)	Spherical Spreading Loss (dB)	Rotator Angle for MRA Alignment (deg)	Pk-Pk Receive Voltage Level at 3.8 kHz (V)	RL @ 1m	
1	3.5	39.21	11.95	21.5	5.1	0.440	183.2	
2	3.0	39.26	11.97	21.6	4.4	0.940	189.8	
3	2.5	39.29	11.98	21.6	3.6	0.660	186.7	
4	2.0	39.32	11.98	21.6	2.9	1.090	191.1	
5	1.5	39.34	11.99	21.6	2.2	0.740	187.7	
6	1.0	39.36	12.00	21.6	1.5	0.736	187.7	
7	0.5	39.37	12.00	21.6	0.7	0.780	188.2	
8	0.0	39.37	12.00	21.6	0.0	0.900	189.4	
9	0.5	39.37	12.00	21.6	-0.7	0.640	186.5	
10	1.0	39.36	12.00	21.6	-1.5	0.720	187.5	
11	1.5	39.34	11.99	21.6	-2.2	0.840	188.8	
12	2.0	39.32	11.98	21.6	-2.9	0.368	181.7	
13	2.5	39.29	11.98	21.6	-3.6	0.344	181.1	
14	3.0	39.26	11.97	21.6	-4.4	0.552	185.2	
15	3.5	39.21	11.95	21.5	-5.1	0.432	183.0	
Combined			12.00	21.6		9.920	210.3	Measured
							210.5	Calculated

**Table 1.** Measured values for individual array transducers and combined output level on-axis (3.8 kHz)

# SOCAL-11 PROJECT REPORT

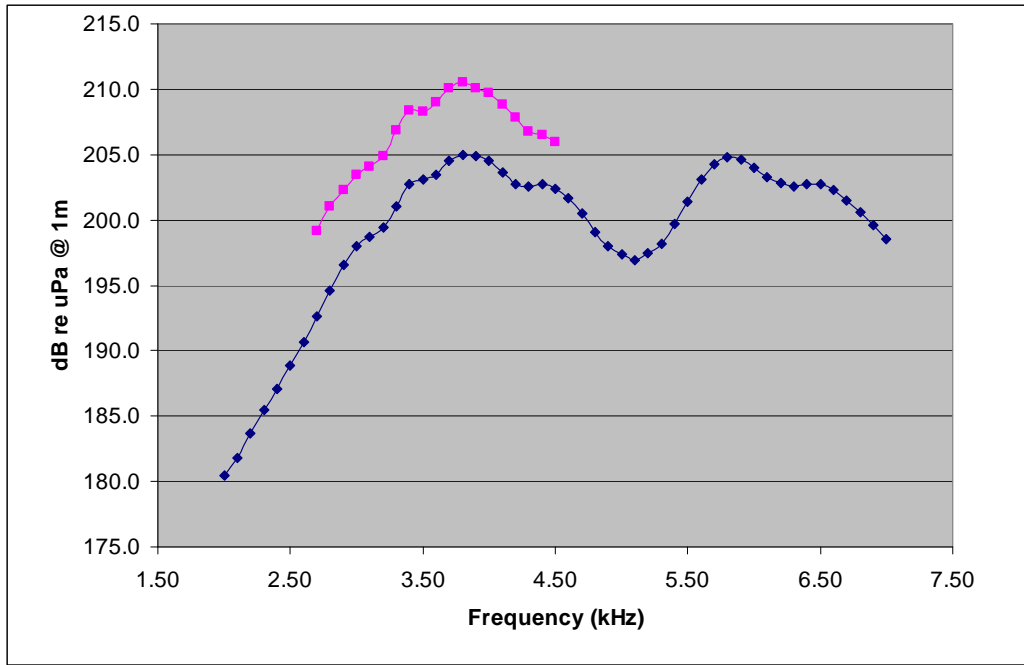

**Figure 2.** 2010 Transmit Voltage Response (TVR) for calibrated for a maximum output at 210 dB (pink) and 205 dB (blue)

Complete MFA and PRN complete playback were executed successfully. The timing and ramp-up sequences were verified. None of the timing irregularities that were negotiated during SOCAL-10 and related to the replaced faulty D/A board were found.

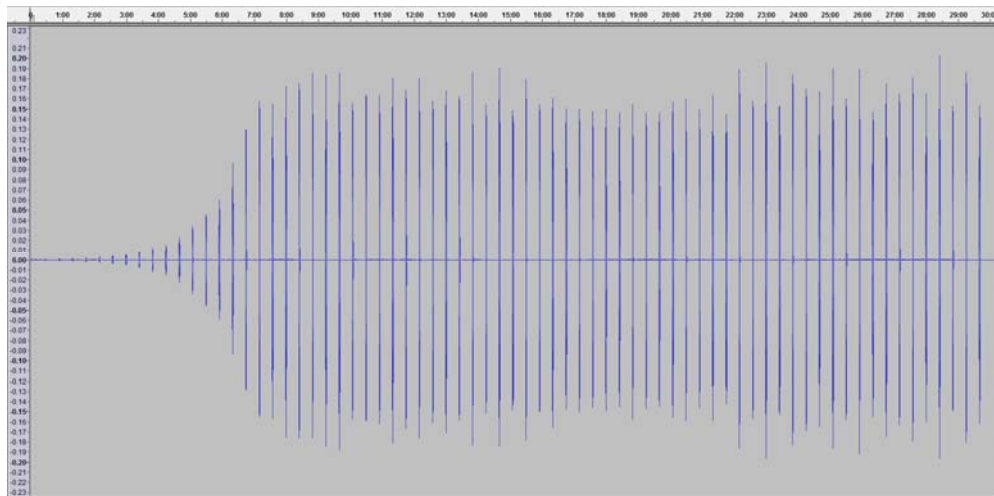

**Figure 3.** MFA 30 minute test run with transmission rate =25 seconds and 50 dB ramp-up in 3 dB steps. Note, the amplitude variation is due to reflections.



# SOCAL-11 PROJECT REPORT

Beam patterns were measured at various steering angles at 3.8 kHz. The array was set at 205 dB level to allow for an increased ping repetition rate which reduced the measurement time. The following measured levels were recorded:

- 204.9 dB at 15 deg (down) steering angle
- 205.5 at 10 deg (down) steering angle
- 206.1 dB at -15 deg (up) steering angle
- 205.3 dB at 0 deg steering angle

At a 0 degree steering angle with the program set to full power (210 dB) a level of 209.7 dB was measured. The full set of beam measured beam patterns are given below.

0 Degree Steering Angle  
(Note plot is rotated ~5 degrees)  
Downward Directed

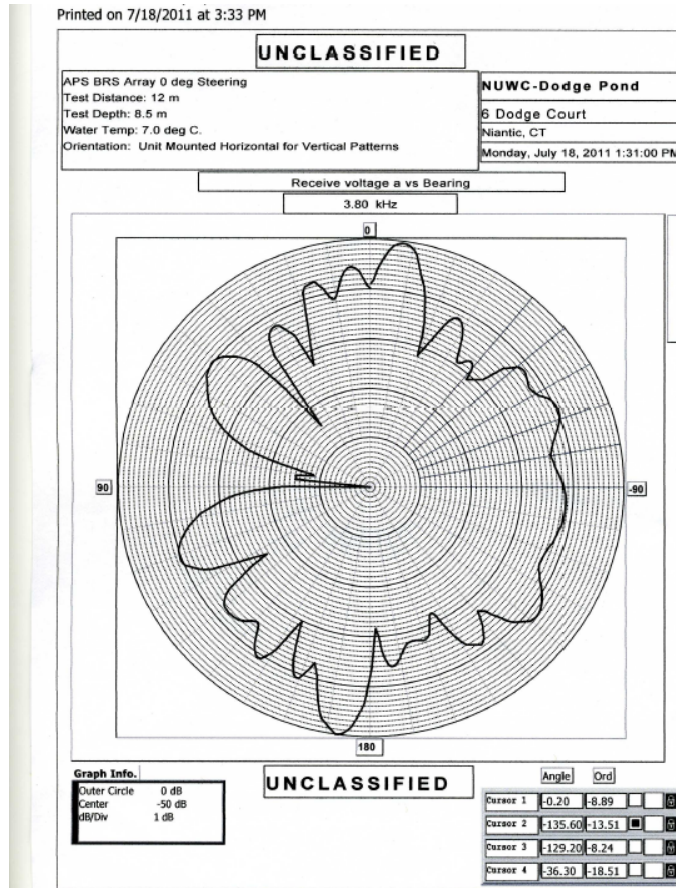

# SOCAL-11 PROJECT REPORT

10 Degree Steering Angle  
 (Note plot is rotated ~5 degrees)  
 Downward Directed

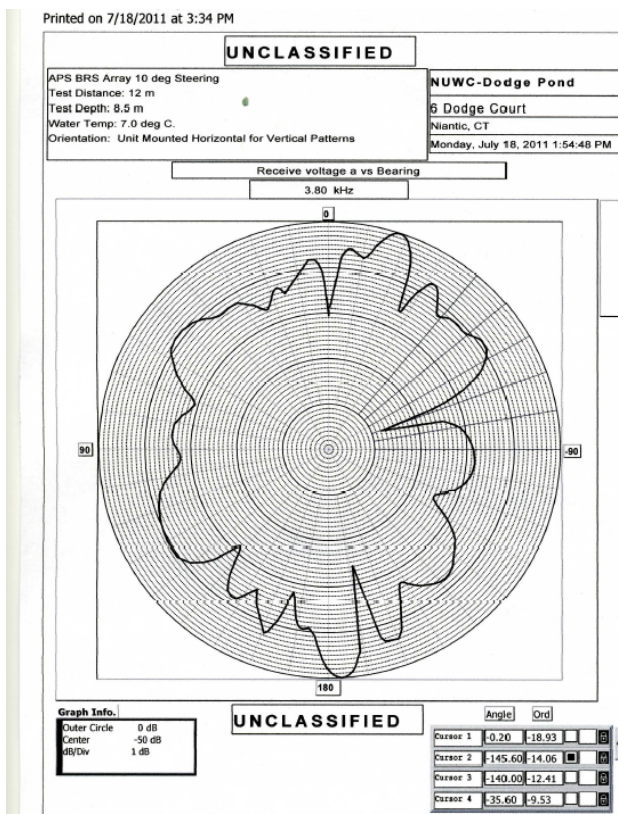

15 Degree Steering Angle  
 Downward Directed

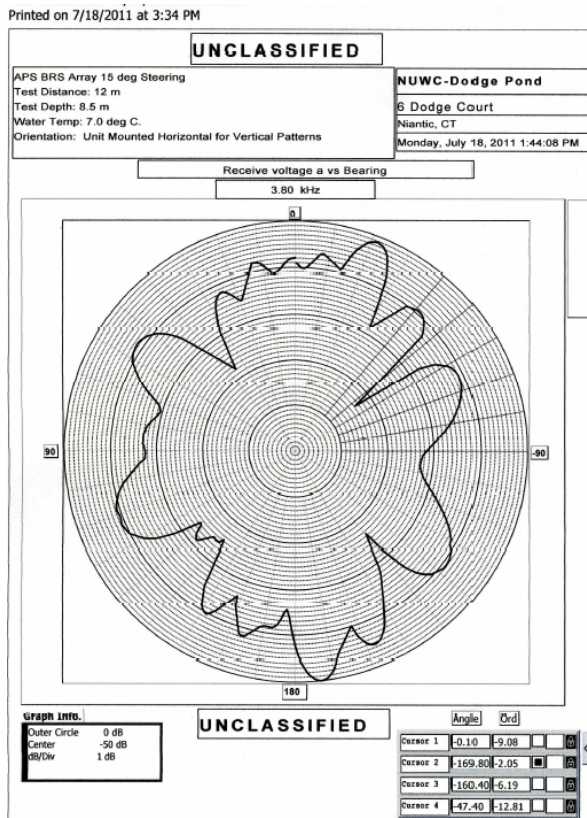

# SOCAL-11 PROJECT REPORT

70 Degree Steering Angle  
Downward Directed

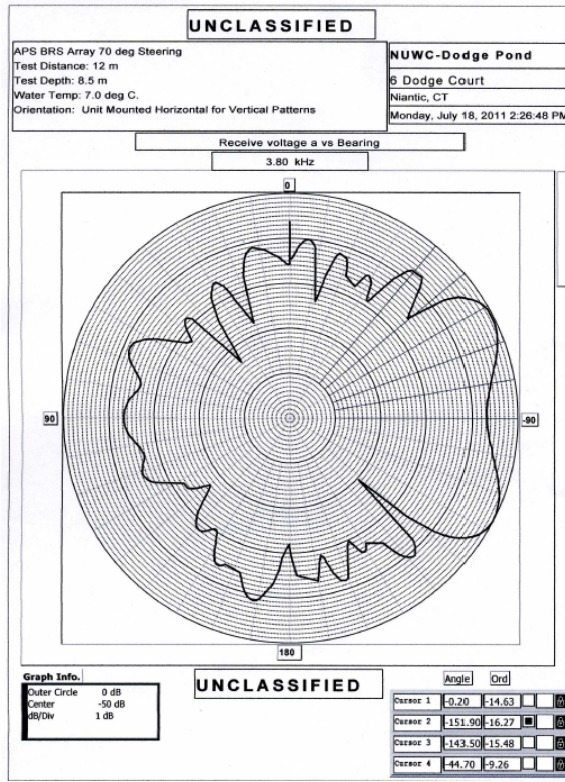

0 Degree Steering Angle with  
Custom Weights

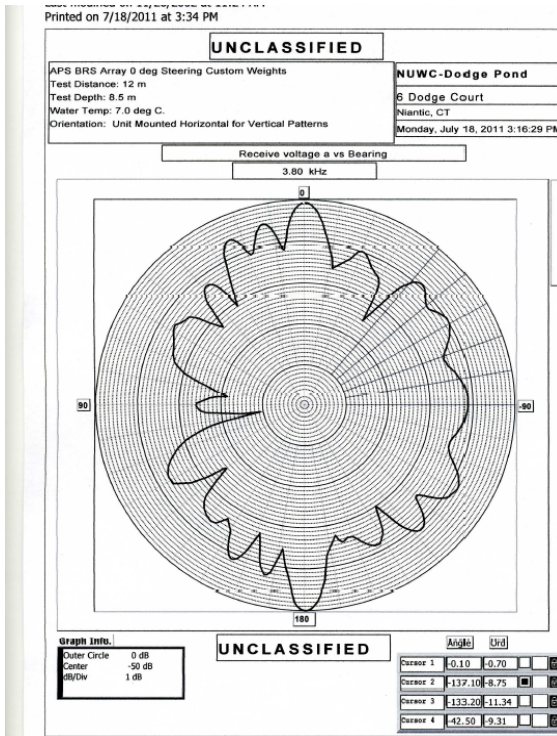

## SOCAL-11 PROJECT REPORT

### 15 Degree Steering Angle Upward Directed

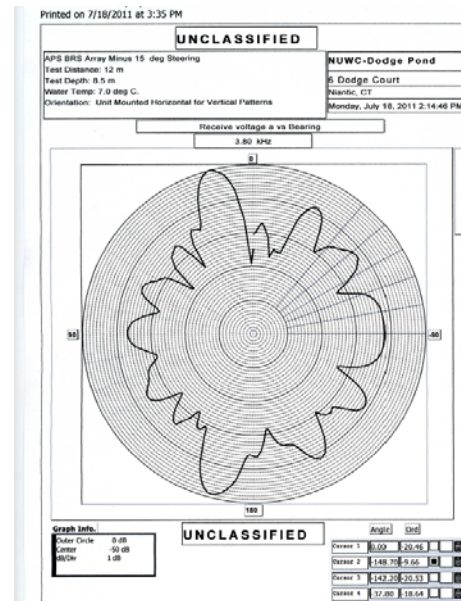

The presence of low frequency out of band energy was investigated. The recording was extremely sensitive to what were believed to be ground-loops within the barge. To mitigate this problem, a recorder running on batteries away from the amplifiers was used to differentially record the F52 calibrated reference hydrophone positioned 12 m from the transmit array. Because the waveform consists of a sweep-CW combination, the FFT analysis is very sensitive to edge effects. The full power 210 dB waveform was recorded at 48 kHz and analyzed in MATLAB. A 16,384 point, Hanning windowed, FFT, with 50% overlap, was used. This provided 3 Hz bandwidth resolution. Low frequency energy was found below 10 Hz at levels 60 dB below the ping at 3.8 kHz). It is not clear that this low-frequency, low energy signal was directly produced by the array. Given the wavelength at 10 Hz (~150 m) and the size of the array (7 m), the sound production mechanism is not obvious. The array was suspended from the middle of a 40 m barge that is supported by air-filled pontoons and connected to shore by a 300 m floating causeway. Separating acoustic, electrical, analysis and physical effects is difficult. During field experiments, sonobuoys can be used to monitor for low frequency signal components. Because of the low source level of the signal (~143 dB), if real, it may difficult to discern above ambient.

## SOCAL-11 PROJECT REPORT

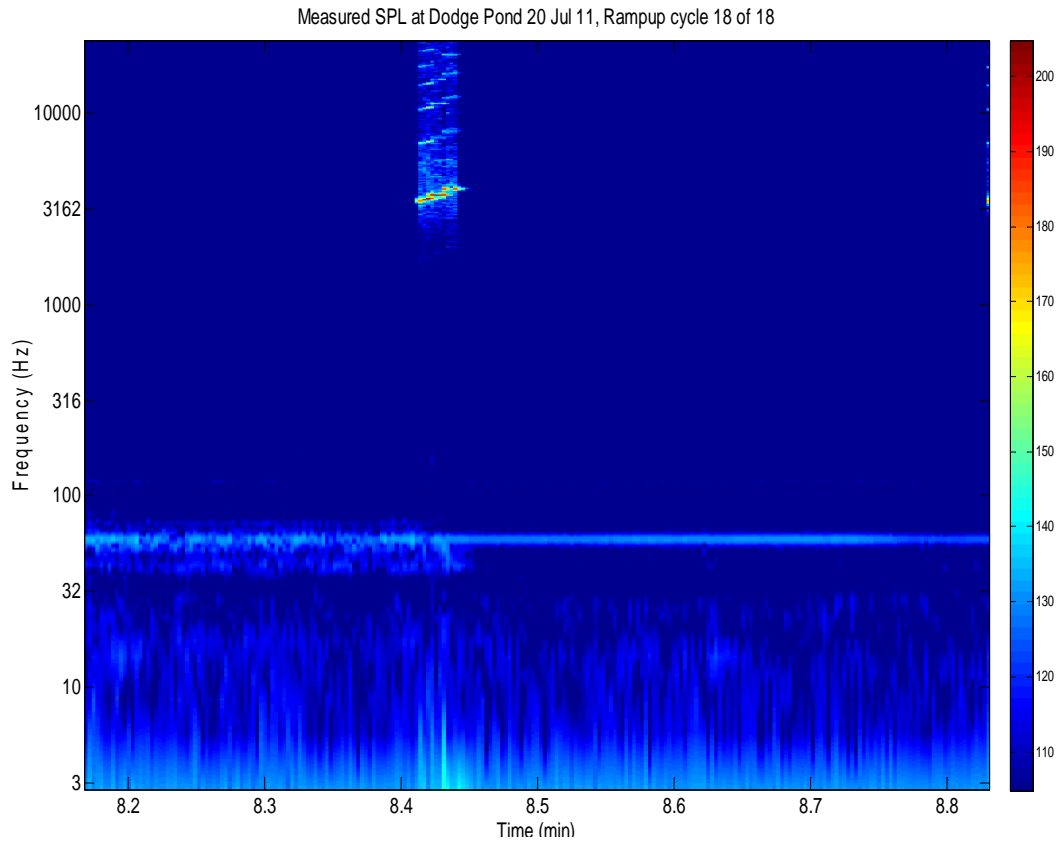

**Figure 4.** Spectrogram of an MFA ping on a log frequency scale. Note, the 50 Hz line and surrounding noise is correlated to a compressor and not related to the MFA transmission.

### Summary

The system was successfully tested. Problems reported during the first field season in 2010 have been addressed. A maximum array source level of 210 dB was verified and closely matches that which was measured in 2010. Changes to the amplifier wiring and enclosure were completed making field modifications significantly more tenable. The ability to steer the beam to various angles was tested. This may prove valuable if playbacks to beaked whales are attempted. The depth sensor and compass have been replaced. All seals were cleaned and o-rings replaced.

## SOCAL-11 PROJECT REPORT

### **APPENDIX II. SOCAL-11 PAM Survey Report: Real-time detection and tracking of beaked whales in the Southern California Bight using a towed hydrophone array**

**Tina M. Yack<sup>1,2,3</sup> Shannon Coates<sup>2</sup>, Jay Barlow<sup>1</sup>, John Calambokidis<sup>4</sup>, Annie Douglas<sup>4</sup>, and Shannon Rankin<sup>1</sup>**

1) NOAA, National Marine Fisheries Service, Southwest Fisheries Science Center, La Jolla, California 92037

2) Bio-Waves Inc., Encinitas, CA 92024

3) Joint Doctoral Program in Ecology, San Diego State University & University of California Davis, San Diego, California 92182

4) Cascadia Research Collective, 218 1/2 W 4th Ave., Olympia, WA 98501

**(Photos: Property of Cascadia Research and taken under NMFS permit #14534)**

#### **APPENDIX II - LIST OF TABLES**

**Table I.** Detailed effort for each survey leg for 2011

**Table II.** Total number of beaked whale encounters based on acoustic data collected during SOCAL-11

**Table III.** Total number of sonar encounters based on acoustic data collected during SOCAL-11

**Table IV.** PAM calibrated recordings of sonar events

**Table V.** Total number of acoustic encounters based on data collected during SOCAL-11

#### **APPENDIX II - LIST OF FIGURES**

**Figure 1.** Tetrahedral array used during SOCAL-11

**Figure 2.** Example of a beaked whale click displayed on a Wigner plot

**Figure 3.** Map of beaked whale encounters

**Figure 4.** Map of sperm whale encounters during SOCAL-11

**Figure 5.** Map of PAM detected sonar events during SOCAL-11

**Figure 6.** PAMGUARD click detection display showing example Cuvier's beaked whale acoustic encounter

**Figure 7.** Example showing the PAM survey position and playback vessel position (Truth) at the time of an acoustic detection of playback sonar

# SOCAL-11 PROJECT REPORT

## I. INTRODUCTION

During SOCAL-11, Passive Acoustic Monitoring (PAM) using towed hydrophone arrays was integrated into the survey plan during the scouting leg and the two experimental legs. The primary objectives of the PAM component were to detect and track beaked whales and sperm whales using their echolocation clicks.

Secondarily, we aimed to implement and test new hardware and software to; 1) increase detection capability through the use of inter-click interval plots and an audible click alarm modules implemented into PAMGUARD software, 2) improve classification accuracy through the use of Wigner plots in real-time to identify upsweeps and 3) increase localization accuracy through the use of a tetrahedral array.

A fourth objective of the PAM survey was to obtain calibrated recordings of the simulated sonar during playback experiments.

## II. MATERIALS AND METHODS

### A. Survey Platforms

This year three vessels served as acoustic research platforms during the SOCAL-11 Behavioral Response Survey within the Southern California Bight. We surveyed for 12 days (15 to 26 July, 2011) during the scouting leg aboard the Truth, a 65-ft motorized platform. During Leg I, a 45 foot sailboat (Green Dragon) was used to survey for five days (2 to 6 August, 2011). And during Leg II a 50 ft. sailboat (Jenny Lane) was used for 12 survey days (17 to 30 September, 2011).

### B. Acoustic Methods

A combination of a five-element linear oil-filled array (with two high-frequency Reson 4013 elements sensitive to 160 kHz and three mid-frequency elements sensitive to 45 kHz) and a 4-element tetrahedral array (**Figure 1, right**) (with four high-frequency elements sensitive to 90 kHz) were used for monitoring acoustic signals. The array was towed 120 meters behind the survey vessel



during daylight hours. We were able to easily switch between arrays through the use of underwater connectors attached to the tow cable. Electrical power on each research platform was noisy; therefore, the acoustic system was designed to run off of 12V deep cycle marine batteries. The computer system included, two 20-inch LG computer monitors, Garmin GPS, Fireface UFX, National Instruments 6251 USB data acquisition board connected to a 12 v fanless computer (Logisys) and a Toshiba laptop plugged into an Isobar filter and powered by a Samlex inverter using AC power.

## SOCAL-11 PROJECT REPORT

PAMGUARD software was used to auto-detect and classify beaked whale echolocation clicks. A bio-acoustician monitored each incoming echolocation signal and used the waveform, spectrum, bearing display, inter-click-interval and Wigner plot (**Figure 2, right**) to help eliminate false detections in real-time. A Wigner plot is a quadratic time-frequency representation (QTFRs) used to analyze the time-frequency structure of broadband cetacean clicks (Papandreou-Suppappola and Antonelli, 2001). Beaked whale clicks were further classified into three subjective

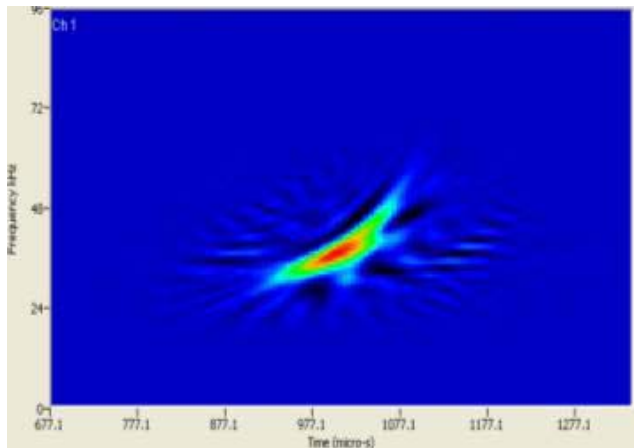

**Figure 2:** Example of a beaked whale click displayed on a Wigner plot.

categories: 1) *possible*, 2) *probable*, and 3) *definite*, based on a number of variables determined by an experienced bio-acoustic technician. Clicks were categorized as ‘possible’ beaked whale detections when at least 5 upsweep clicks (based on the Wigner plot) were automatically detected in PAMGUARD. Clicks classified as beaked whale using the automated detection in PAMGUARD with at least 5 upsweeps in the Wigner plot that were verified by a senior bio-acoustic technician using the real-time spectrogram and determined to have the proper inter-click-interval, were categorized as ‘probable’ detections. Clicks that were acoustically classified as probable with an associated visual sighting of a beaked whale were categorized as ‘definite’ However, if there was strong evidence that a beaked whale was acoustically detected (clear beaked whale click trains with the proper inter-click-interval) without a visual confirmation, these would also be classified as a definite detection.

### *C. Calibrated Sonar Recordings*

Sonar calibration recordings were made using a Korg MR-1 digital recorder at a 24-bit, 192 ks/sec setting and a Reson 4033 (flat response 2-80 kHz) calibrated hydrophone on a 50m cable. Unless otherwise noted, recordings were made with 45m of cable deployed. Input was routed to the left channel of the Korg MR-1 with the Mic/Line selection switch set to Mic and pre-amp gain set to +10dB.

### *D. Visual Methods*

A team of 2-3 scientists were used on each platform (Truth, Green Dragon and Jenny Lane) to gather visual observations during SOCAL-11. While aboard the sailboat platforms, observers rotated between two visual positions. Each observer was positioned on one side of the vessel and scanned the horizon (0-90 degrees in relation to the ship's heading) using handheld 7x50 binoculars or their naked eye. In addition to



## SOCAL-11 PROJECT REPORT

the sailboat observers, typically, another team of two scientists surveyed within close proximity to all vessels from an inflatable rigid hull boat (RHIB, ~5.5 m) during daylight hours. All marine mammal sightings were documented using the appropriate forms and later entered into the acoustic sighting form database. Photo identification was collected opportunistically as conditions allowed.

### III. RESULTS

#### A. Effort

During 28 days of effort we surveyed over 2000 kilometers of trackline and recorded over 219 hours of acoustic data (**Table 1**).

**Table 1.** Detailed effort for each survey leg of 2011.

Leg	Vessel	Effort Days	Recording Hours	Kilometers Effort
Scouting	Truth	10	91:27:00	1025
Leg 1	Green Dragon	5	37:01:00	289
Leg 2	Jenny Lane	13	91:09:00	718
Total	-	28	219:37:00	2032

#### B. Beaked Whales

During the SOCAL-11 PAM survey there were 4 confirmed beaked whale sightings, which include 3 different species, Bairds (*Berardius bairdii*), Cuvier’s (*Ziphius cavirostris*), and an unidentified small *Mesoplodon*. There was an additional sighting of an unidentified beaked whale (**Figure 3**). Three of these encounters were first detected acoustically. The other two (Cuvier’s) were first detected visually but near the same area of acoustic detections from previous days. The unidentified *Mesoplodon* was 12 nautical miles offshore of San Diego and acoustics had detections in this area consistently over a three day period. The visual sighting occurred on the 3rd day when the weather was less than Beaufort 3.

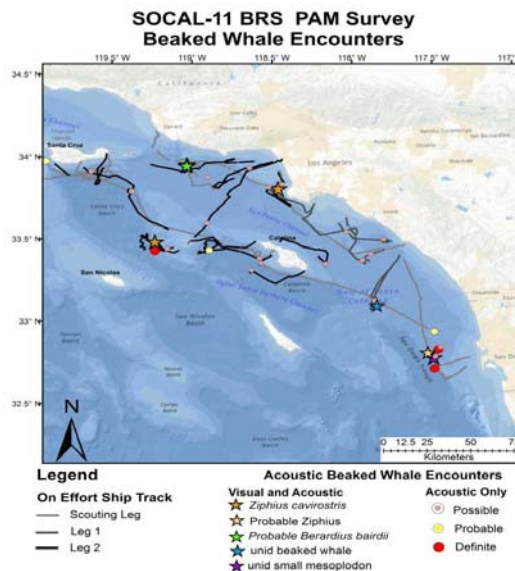

**Figure 3:** Map of beaked whale acoustic encounters.

In addition to the 4 confirmed beaked whale sightings, there were a total of 20 possible detections, 6 probable detections and 3 definite detections of acoustic only encounters without a visual confirmation (**Table 2, below**).

# SOCAL-11 PROJECT REPORT

**Table 2:** Total number of beaked whale encounters based on acoustic data collected during SOCAL-11

Beaked Whale Encounter Category	Detection Type		
	Acoustic	Visual & Acoustic	Total
Definite	3		3
Definite <i>Ziphius cavirostris</i>		2	2
Possible	20		20
Probable	3		3
Probable <i>Berardius bairdii</i>	1	1	2
Probable <i>Ziphius cavirostris</i>	1		1
Unid beaked whale	1		1
Unid small <i>Mesoplodon</i>		1	1
<b>Total</b>	<b>29</b>	<b>4</b>	<b>33</b>

### C. Sperm Whale Encounters

During the survey legs there were two definite and two probable sperm whale acoustic detections, however none of these were successfully located visually (**Figure 4, right**).

### D. Sonar Event Detection

During the survey sonar was detected on 28 occasions (**Table 3, below**). Of these 8 were from Naval sonar exercises and 7 were from SOCAL-11 associated playback experiments. There were 13 events defined as other, which included echosounders and unknown types of sonar (**Figure 4, right**).

**Table 3:** Total number of sonar encounters.

Sonar Type	Number of Detections
Echosounder	4
Naval	8
Playback	7
Unknown	9
<b>Total</b>	<b>28</b>

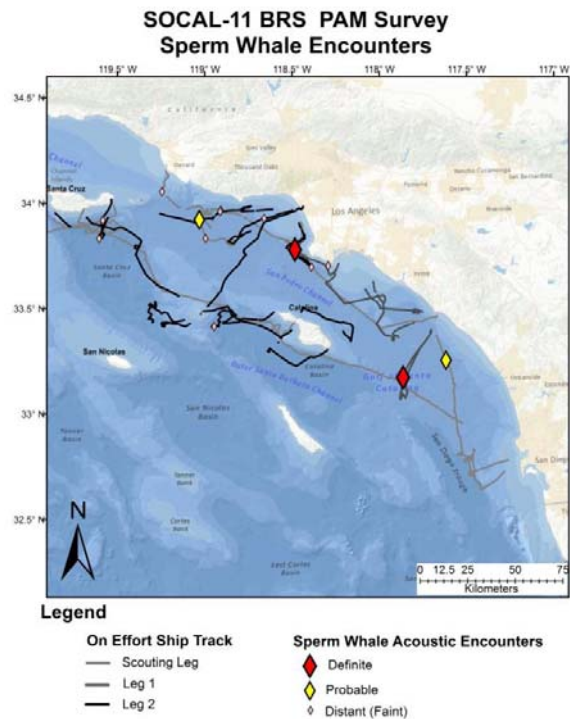

**Figure 4:** Map of sperm whale acoustic encounters.

## SOCAL-11 PROJECT REPORT

Calibrated recordings were made of 3 playback experiments and 1 Naval sonar exercise. One playback was of Pseudo Random Noise and the other 2 were simulating navy sonar (**Table 4, below; Figure 5, right**). The average received levels ranged from 85 – 109 dB re: 1 $\mu$ Pa for the playback experiments. The average received level from the Naval sonar exercise was 81 dB re: 1 $\mu$ Pa.

**Table 4.** PAM calibrated recordings of sonar events.

Date	Description	Lat	Long	Avg. Received Level (dB re: $\mu$ Pa)	Range (dB re: $\mu$ Pa)
9/22/2011	Playback: Pseudo Random Noise	33.29	-118.66	85	(81 - 84)
9/24/2011	Navy Sonar	33.52	-119.29	81	(78 - 83)
9/24/2011	Playback: Ziphius	33.44	-119.31	115	(86 - 136)
9/26/2011	Playback: Distant > 20 km	33.73	-118.48	109	(102 - 113)

### E. Other Species Detections

In addition to the beaked whale, sperm whale and sonar detections, there were a total of 5 dolphin species identified both acoustically and visually, 54 unidentified *Delphinus* species, 17 unidentified cetaceans, 87 unidentified dolphins, and 1 mixed group of identified dolphins (**Table 5**).

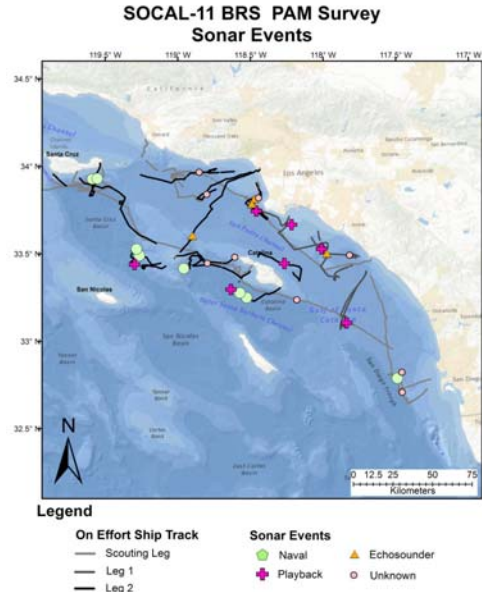

**Figure 5.** Map of PAM detected sonar events

**Table 5:** Total number of acoustic encounters during PAM survey effort for SOCAL-11.

Species ID	Detection Type		Total
	Acoustic Only	Visual and Acoustic	
<i>Delphinus capensis</i>		24	24
<i>Delphinus delphis</i>		7	7
<i>Delphinus</i> sp.	1	53	54
<i>Grampus griseus</i>	1	17	18
Mixed School: <i>Grampus griseus</i> & <i>Turisops truncatus</i>		1	1
<i>Turisops truncatus</i>		17	17
unid cetacean	16	1	17
unid dolphin	64	23	87
<b>Total</b>	<b>97</b>	<b>143</b>	<b>240</b>

## IV. DISCUSSION

### A. Survey Platforms

On the scouting leg PAM was implemented from the TRUTH (motorized) survey vessel. The TRUTH was electronically noisy, but propeller cavitation was less of a problem at 6-8 kts than the sailing vessels. During the experimental legs we used two different sailing platforms which varied greatly in their effectiveness. The 45 foot platform was designed

## SOCAL-11 PROJECT REPORT

as a racing sailboat which was too small, too slow and too noisy for towed array work. It also did not have radar or good navigation abilities and had power charging and anchoring constraints that made it impossible to anchor offshore. Not being able to anchor offshore hindered our ability to survey various portions of the deep canyons off of the Channel Islands and forced us to leave marine mammal sightings early in order to return to shore nightly. The 50 foot platform was much improved in all areas but our abilities were still constrained by the limited speed that we could travel and survey. The maximum speed of the vessel while the engines were on was approximately 4-5 knots while we were in PAM mode which was determined to be the best for detecting beaked whales. An increase in speed caused additional ship noise and drowned out any chance for beaked whale detections. Even though we had the option to sail with the engines off, the calmer weather experienced slowed our travel speed. The reduction of recording and survey effort during sailing legs is a reflection of long transits without the array in the water so that we were able to travel at higher speeds.

### *B. Beaked Whale Detection and Tracking*

Beaked whale detection and tracking during the SOCAL-11 PAM survey was improved from previous seasons by the implementation of new software and hardware tools. The PAMGUARD software improvements included Wigner Plots, which can be used to positively differentiate beaked whale clicks from other odontocete species by visually confirming the presence of a frequency modulated upsweep in the echolocation click. Additionally, an Inter-Click Interval (ICI) display was added. This feature was utilized late in the field season and needs further modification to be more useful. Hardware improvements included a tetrahedral array design that enabled 3-D tracking of echolocation clicks. This feature was extremely useful for dolphins but the hydrophone sensitivity was not equal on all hydrophones limiting its utility for beaked whales during the SOCAL-11 season. Modification of the array design will improve our capabilities for beaked whale tracking during SOCAL-12. Another improved hardware design was the use of an underwater connection which enabled us to easily switch between the tetrahedral array and a linear array.

There was one Cuvier's beaked whale encounter during SOCAL-11 that resulted in a successful playback. The group was first detected visually by the Truth and later joined by the PAM survey vessel. The encounter occurred within 6 kilometers of a previous acoustic only detection. During this encounter the PAM team was able to assist in tracking the group throughout the ~10 hour encounter period. We recorded two deep dives during which echolocation click trains were detected and tracked. Clicking was detected over a period of ~35 min during the first deep dive and ~41 min during the second deep dive. Figure 6 (below) shows an example of our PAMGUARD detection display during the playback. This figure illustrates the bearing time display at the top showing the bearing from the ship along the y axis and time along the x (**Figure 6a**), the waveform showing amplitude as a function of time (**Figure 6b**), the spectrum showing frequency as a function of amplitude (**Figure 6c**) and a Wigner plot depicting the

## SOCAL-11 PROJECT REPORT

upswept characteristic of a beaked whale click (**Figure 6d**). In the time bearing display we are able to track 4 different animals in the example shown.

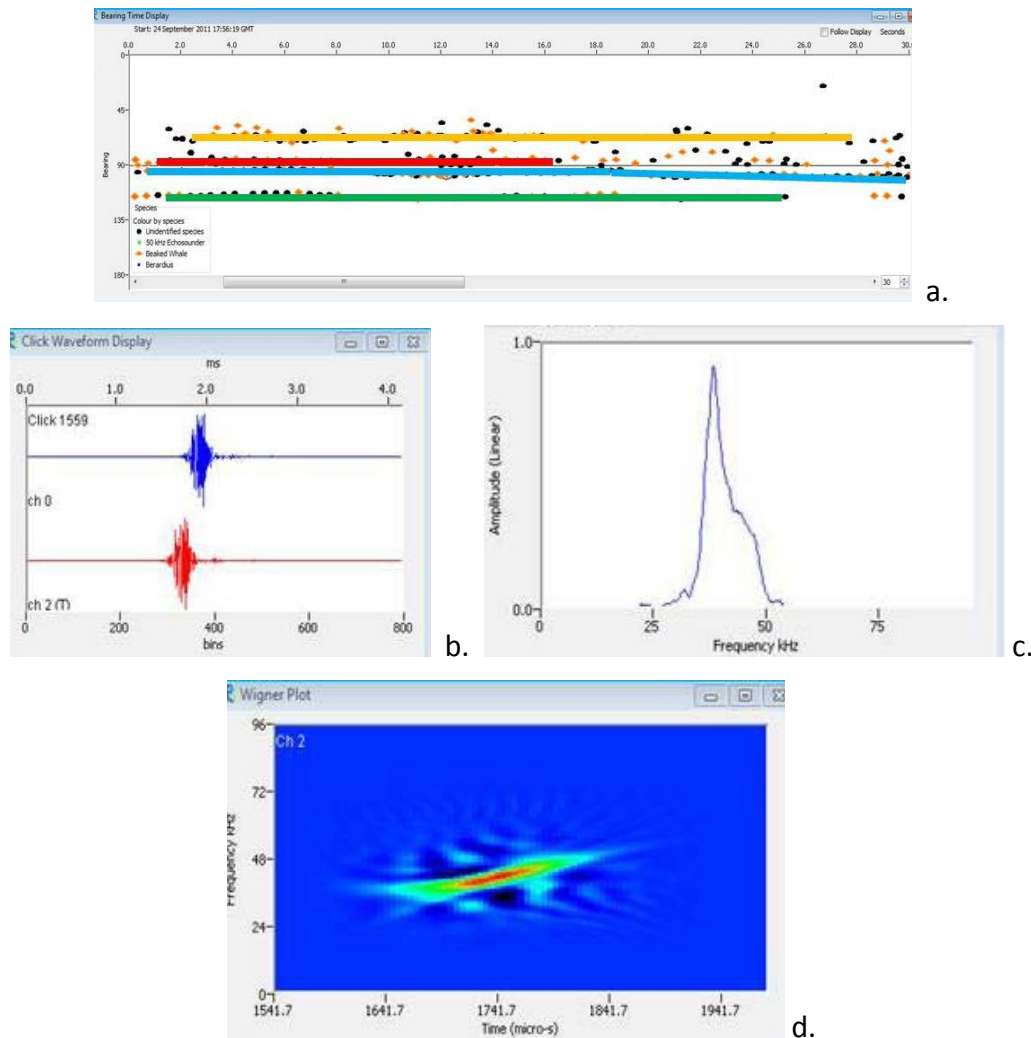

**Figure 6.** PAMGUARD click detection display showing example Cuvier's beaked whale acoustic encounter (a) bearing time display, (b) waveform, (c) power spectrum and (d) Wigner plot. Colored lines represent bearing angle trajectories for individual whales.

### *C. Sperm Whale Encounters*

There were a few occasions that we spent several hours trying to acoustically track sperm whales during SOCAL-11 to obtain a visual sighting without success. We believe our lack of success was because sperm whale clicks can be detected over 20 km away and at greater distances for loud male 'clangs', additionally the complex bathymetric features of the Southern California Bight likely cause distortion in the arrival angles of echolocation clicks. In the future we recommend only tracking loud regular feeding clicks from sperm whales. During the 2010 survey PAM was able to successfully track

## SOCAL-11 PROJECT REPORT

and assist in visually locating a sperm whale using this approach.

### D. Sonar Event Detection

Playback sonar was initially detected during the first experimental leg when the PAM vessel was over 25km away from the Playback vessel (**Figure 7, left**). At this point the



utility of using the PAM vessel to make calibrated recordings of playback sonar was realized. Calibrated recordings were made throughout the second experimental leg whenever playback sonar was detected. We believe this is a beneficial compliment to the suite of data that can be collected by the PAM survey team and we recommend that this practice is continued

during SOCAL-12.

**Figure 7.** Example showing the PAM survey position (red) and playback vessel position (green) at the time of an acoustic detection of playback sonar. In this example playback sonar was detected at a distance of ~25 km.

### E. Other Species Detections

During SOCAL-11 the PAM survey team kept a thorough database of all species detected visually and acoustically. While this information may be useful on some level to describe distribution of marine mammals in the Southern California Bight it is of little to no quantitative value. As such, in future SOCAL efforts overall costs could be decreased by utilizing fewer acoustic technicians. It is recommended that this option be discussed during the SOCAL-12 planning meeting.

## V. CONCLUSIONS

In summary, our SOCAL-11 data illustrates that our detection ability has improved greatly over the past 3 years and real-time Wigner plots have practically eliminated false detections. We have also improved our classification and can now fairly reliably distinguish Cuvier's from Baird's and *Mesoplodon* beaked whale species in real-time. However, although we have more tools for localization there is still room for improvement, especially in estimating ranges more accurately and getting better bearings from the tetrahedral array to predict surfacing within a few hundred meters of the tagging vessel. Finally, our studies indicate that beaked whale encounters in distinct regions seems stable over time.

## SOCAL-11 PROJECT REPORT

Our future needs and goals are for continued improvement of localization software and hardware with better bearing mapping and range estimation utilities and continued improvement of species ID for beaked whales. We are really lacking good acoustic/visual confirmations for *Mesoplodon* species. Additionally, we think our capabilities and effort could be significantly improved with a platform that could transit more quickly and tow at higher speeds.

### **VI. ACKNOWLEDGEMENTS**

We would like to acknowledge our funding sources, namely ONR and Navy N45. Additionally we would like to thank the captains and crews of the survey vessels and all of the participants of the surveys including; Sophie Webb, Suzanne Yin, Barb Taylor, Danielle Cholewiak and Alison Stimpert for field assistance. A special thanks to Brandon Southall and our SOCAL- 11 BRS collaborators for inviting us to participate in the BRS study, and Doug Gillespie and Mike Oswald for PAMGUARD software support.

### **VII. LITERATURE CITED**

Papandreou-Suppappola, A., Antonelli, L. 20 December 2001. Use of Quadratic Time-Frequency Representations to Analyze Cetacean Mammal Sounds. *NUWC-NPT Technical Report*.